

For the use of UPS BH60PCW/BH100PCW

- This manual contains important information regarding the safe use of the BHM60PC/BHM100PC for the Backup Power Supply BH60PCW/BH100PCW. Please read these instructions before installing and/or using the product.
- Please connect and install the battery unit only after having fully understood the relevant procedures for the Backup Power Supply, found in the Backup Power Supply BH60PCW/BH100PCW Instruction Manual.

Safety precautions

This manual contains important information regarding the safe use of this product.

Please read these instructions before installation and/or use.

- The safety symbols used in this manual are explained below.

	Warning	Indicates an imminently hazardous situation which, if not handled properly, may result in death or serious injury.
	Caution	Indicates a potentially hazardous situation which, if not handled properly, may result in injury or property damage.

* Property damage means damage to houses/household effects, livestock, and pets.

- : Indicates a prohibited action (something you must not do). For example, indicates that disassembly is prohibited.
- : Indicates a necessary action (something you must do). For example, indicates that grounding is necessary.

Note that some items described as cautions may result in more serious damage under certain conditions. The information described here is very important and must be strictly observed.

Warning (product use)

Do not use this product in applications which require an extremely high degree of reliability and safety, such as those listed below.

(This product is designed and manufactured for use for FA/OA equipment such as personal computers.)

- Medical equipment or system that may cause death directly
- Applications that directly affect the safety of people. (For example, the operation and control of cars and elevators.)
- Applications in which failure may significantly damage or impact the society and public. (For example, important computer systems or communication equipment.)
- Applications with the same level of importance as those described above.

Caution (installation)

The weight of the BHM60PC is 8.2 kg, and the weight of the BHM100PC is 10.3 kg. Carefully consider the weight when unpacking/transporting this product.

- Injury may result if the unit falls or is dropped.

Do not disassemble, repair, or modify the product.

- Doing so may cause an electric shock or a fire.

Place the unit on a level, stable and solid surface.

- Injury may result if the unit falls or is dropped.
- The weight of the unit is approximately:
 BH60PCW(RE60FW): 6.3kg BH100PCW(RE100FW): 6.6kg
 Battery unit BHM60PC: 8.2kg Battery unit BHM100PC: 10.3kg
- If you drop the unit, stop using it and have it inspected and repaired.

Keep plastic bags out of the reach of children.

- Children may suffocate if they put their heads into plastic bags.

Do not use the product where the maximum temperature exceeds 55°C.

- The battery weakens rapidly, and may cause a fire.
- Doing so may cause the unit to fail or malfunction.



Caution (installation)

Do not exceed the ranges specified for environmental conditions during use/ storage.



Do not install or store the unit in the types of places listed below.

- Do not store the unit in places where the humidity is lower than 10% or higher than 90%.
- Do not use the unit in places where the humidity is lower than 25% or higher than 85%.
- Do not install/store the unit in closed places such as cabinets with no clearance, places where there is flammable or corrosive gas, or outdoors.
- Installing or storing the unit in such places may cause a fire.

Do not block the air vents.



Do not use the product in a closed place and/or do not cover the product.

- Doing so may cause abnormal heating or a fire.
- Doing so will cause the internal temperature to rise, which may cause the unit to fail and the battery to deteriorate.
- Leave at least 5 cm of space between the vent and the wall.

Do not install the unit in any position other than those specified.



Do not install the unit on an unstable base.

- Refer to "2-1 Installation" on page 4 for proper installation positions.
- Injury may result if the unit falls or is dropped.

Do not pinch or tie the cable of the unit.



- Doing so may damage the cable or cause it to become hot, resulting in an electric shock or a fire.
- If the cable is damaged, immediately stop using the unit and have it repaired.

All of the included accessories are designed to be used exclusively with the unit. Do not use the accessories with other devices.



- Doing so may compromise the safety of devices.

When installing the unit on a rack, use support angles (sold separately) and mounting brackets to support and stabilize the unit.



When a battery unit is added, make sure to position the battery unit so that it is below the main unit.

- When installing the unit on a rack, use support angles (sold separately) and mounting brackets. The front mounting brackets are not able to support the weight of the unit without support angles.
- The weight of the unit is approximately:
BH60PCW(RE60FW): 6.3kg BH100PCW(RE100FW): 6.6kg
Battery unit BHM60PC: 8.2kg Battery unit BHM100PC: 10.3kg

When installing the unit on a rack, place it on the lowest shelf.



- Injury may result if the unit falls.

Make sure to use the mounting screws included with the brackets (sold separately).



- Mounting screws other than those included may not be strong enough to support the unit, causing it to fall.

Caution (use)

If you notice an abnormal sound or smell, smoke or leaking fluid,

- Immediately turn OFF the UPS power output switch () , and disconnect the AC input plug from the wall outlet (commercial power) and disconnect the battery connector (with Red and Black code) from the UPS rear panel.



If fluid leaks from the battery, do not touch it.

- Doing so may cause blindness or burns.
- If it touches your eyes or skin, wash it out with lots of clean water and consult your doctor.



Do not use the product in a closed place and/or do not cover the product.

- Doing so may cause abnormal heating or a fire.



Do not pour water on the unit and do not allow it to become wet.

- Doing so may cause an electric shock or a fire.
- If the unit becomes wet, immediately stop using it and have it inspected and repaired.



When the battery replacement indicator starts to blink, or when the backup time becomes shorter than the required time, immediately stop using the unit and replace the battery pack.

- Continuing to use the unit may cause a fire.
- For more on how to check the battery, see "5. Maintenance and Inspection" on page 49 of the BH60PCW/BH100PCW instruction manual.



Ambient temperature	Expected life
20°C	5 to 7 years
30°C	3 to 4 years
40°C	1.5 to 2 years
50°C	0.7 to 1 years

* The values in the table on the left reflect the expected life under standard use conditions and are not guaranteed values.

Caution (battery replacement)

Battery can be replaced while the unit is stopped only.

- When replacing the battery, stop the connected devices, turn off the power supply (UPS) output switch () , and disconnect the AC input plug from the wall outlet.



Do not insert metal objects into the battery connectors.

- Doing so may cause an electric shock.



Do not short the battery with metal objects.

- Doing so may cause an electric shock, fire or burn.
- Some electrical energy remains inside the spent battery.



Do not put the battery into fire.

- The batteries may explode.



Replace batteries only with the same model and brand:

- Battery pack models: BHB60PC: For BHM60PC battery unit (BH60PCW).
BHB100PC: For BHM100PC battery unit (BH100PCW).
- Manufacturer: OMRON Corporation.
- Using a battery other than that which is specified may cause a fire.



Risk of explosion if battery is replaced by an incorrect type.

Dispose of used batteries according to the instructions.



Do not use a new battery and an old battery at the same time.

- Doing so may cause the battery to leak dilute sulfuric acid.



Caution (battery replacement)

Do not drop the battery or expose it to strong impact.

- Doing so may cause the battery to leak dilute sulfuric acid.



Do not replace the battery in a place where there is flammable gas.

- A spark may occur when connecting the battery, which may cause an explosion or fire.



Perform replacement on a stable and flat surface.

- Handle the battery carefully so that you do not drop it.
- Dropping the battery may result in injury or burns due to leakage (acid).



If fluid (dilute sulfuric acid) leaks from the battery, do not touch it.

- Doing so may cause blindness or burns.



Do not open or mutilate batteries.

- Released electrolyte is harmful to the skin and eyes. It may be toxic.



Notes

When moving the unit from a cold place to a warm place, leave it for several hours before using it.

- If the unit is promptly turned ON after being moved to a warmer place, condensation may form inside the unit and cause it to fail.

Do not install or store the unit in a place exposed to direct sunlight.

- Doing so may cause the unit to fail or malfunction.
- A rise in temperature may cause the built-in battery to deteriorate rapidly and become unusable.

Charge the battery immediately after purchase.

- If you do not use the unit for a long time after purchase, the battery performance may deteriorate and it may become unusable.
- The battery can be charged once the AC input plug of the UPS is connected to a wall outlet (commercial power).

When storing the UPS, charge the battery and turn OFF the power switch.

- The battery discharges even when it not being used, and it goes into over discharge state if it is left for a long period of time. The backup time may become shorter or the battery may become unusable.
- The storable period of the built-in battery of the UPS is 6 months after being fully charged.
- When storing the battery for more than 6 months, connect the AC input plug of the UPS to a commercial power wall outlet before 6 months has elapsed.
- Turn OFF the power switch of the UPS during storage.

This unit uses a lead acid battery.

- Lead acid batteries are a valuable recyclable resource. Please recycle.
For information about recycling, please contact our Electronic Systems & Equipments repair center.



1. Preparation

1-1 Unpacking the product

Open the package box and take out the additional battery unit and accessories.

- Battery unit for BH60PCW: BHM60PC
- Battery unit for BH100PCW: BHM100PC

1-2 Checking the accessories

Make sure that all accessories are included and that there is no external damage.

If you notice any defects, immediately contact the shop of purchase.

1. Instruction manual	1
2. Battery connection cable	1
3. Battery connector covers.....	2
4. Connector cover mounting screws	2
5. Signal cable	1
6. Warranty card	1



Instruction manual

Warranty card



Battery connection cable

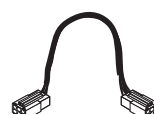

Signal cable

2. Adding/connecting a battery unit

2-1 Installation

- The procedure for adding a battery unit is explained here.
Battery units can only be added for the BH100PCW UPS only.
Battery units cannot be added to the 600VA type BH60PCW UPS.
- Up to 5 battery units can be connected to the BH100PCW UPS.
*When using the unit in compliance with UL standards, a total of up to 2 battery units can be connected.
Do not connect more than 2 units.
- For information about units with no additional battery units connected, refer to the BH100PCW/BH60PCW instruction manual.

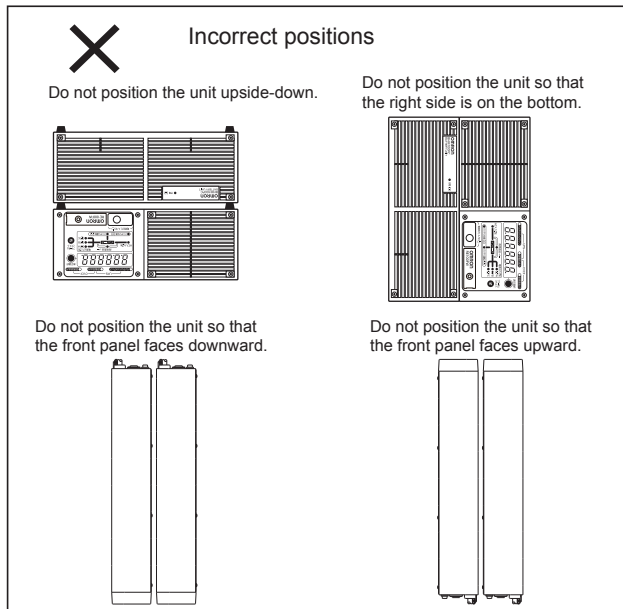
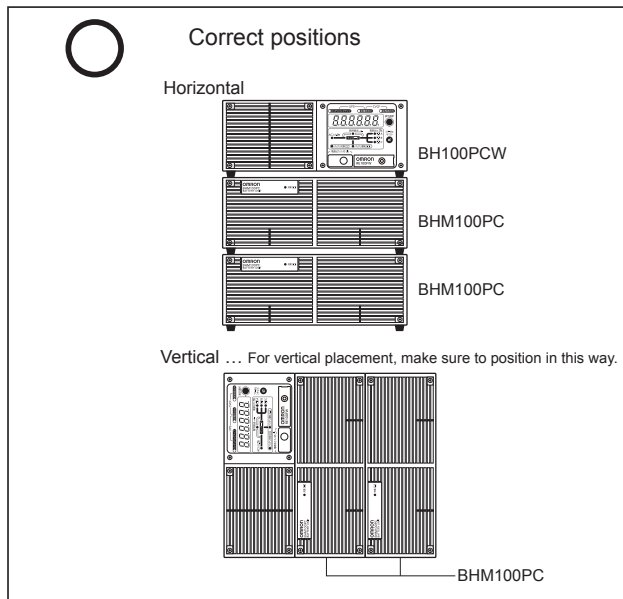

Rack-mount installation

- When attaching to a rack, detach the rubber feet from the bottom surface of the unit.

When using an EIA 19-inch rack

- When attaching to the rack, use BHP60P mounting brackets (sold separately) to connect the UPS body with the battery unit. For details, refer to the instruction manual included with the rack-mount brackets (BHP60P) and support angles (BUP06).

When using a JIS 19-inch rack

- When attaching to the rack, use BHP60J mounting brackets (sold separately) to connect the UPS body with the battery unit. BUP06 support angles are not compatible with JIS standards. Use a rack shelf.

For details, refer to the instruction manual included with the rack-mount brackets (BHP60J).

For details, refer to the instruction manual included with the rack-mount brackets (BHP60P) and support angles (BUP06). Support angles are not compatible. Use a server rack.

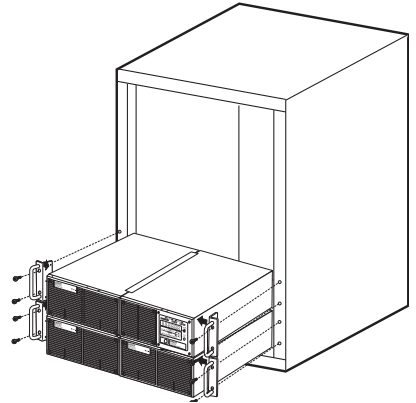

Use support angles (BUP06) to support each unit that is joined.

2-2 Connecting the battery unit

- Up to 5 battery units can be connected to the 1kVA-type BH100PCW.
- Additional battery units also use the same model of BHM100PC (for 1kVA) as the first unit.

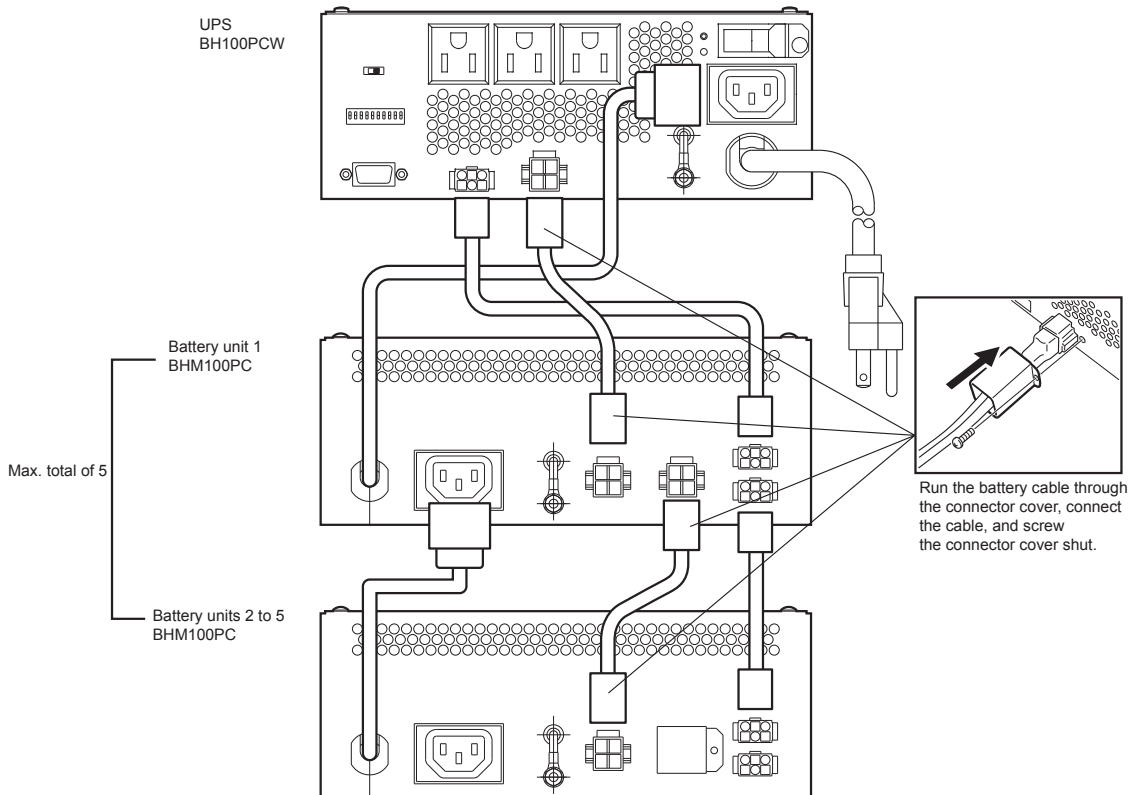

*When adding a BHM100PC, remove the connector attached at shipment and connect the cable.

- Each battery unit is equipped with a charging circuit. The charging time does not increase when a battery unit is added.

3. Replacing the battery pack

The battery can be replaced only while the UPS is stopped (power supply output stopped).

⚠ Caution

When an UPS is used in compliance with UL, CE standards, do not replace the battery while in operation (while power is being output). Replacing the battery while in operation does not comply with UL, CE standards. Replace the battery while UPS operation is stopped.

* To replace the battery while the UPS is stopped, stop the connected devices, turn OFF the power switch of the UPS, and disconnect the AC input plug from the wall outlet.

This unit uses a lead acid battery.

- Lead acid batteries are a valuable recyclable resource. Please recycle.
For information about recycling, please contact our Electronic Systems & Equipments repair center.



● Preparation

(1) Purchase a spare battery pack (sold separately).

- Battery pack for BHM60PC: BHB60PC
- Battery pack for BHM100PC: BHB100PC

● Battery replacement

(1) Loosen the 4 screws on the front of the unit and remove the front panel.

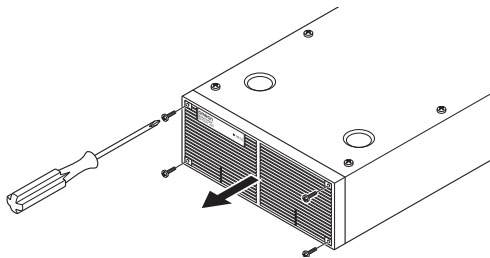

Be careful not to lose the screws that you remove.

(2) Disconnect the 2 battery connectors, and loosen the 4 screws to remove the fixing bracket.

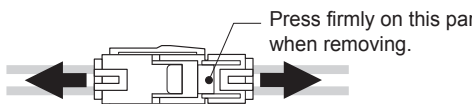
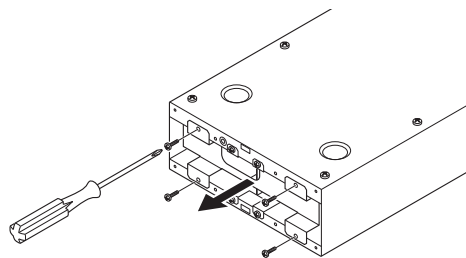
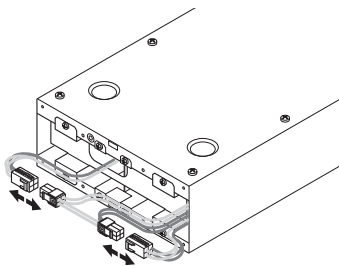

(3) Remove the battery.

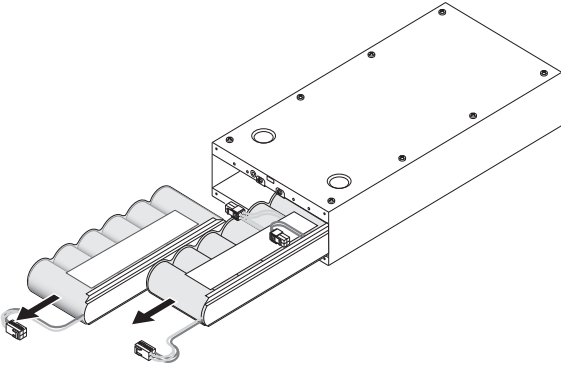

- Hold the battery firmly and slide it out.

⚠ Be careful not to drop the battery.

(4) Insert the new battery and attach the fixing bracket.

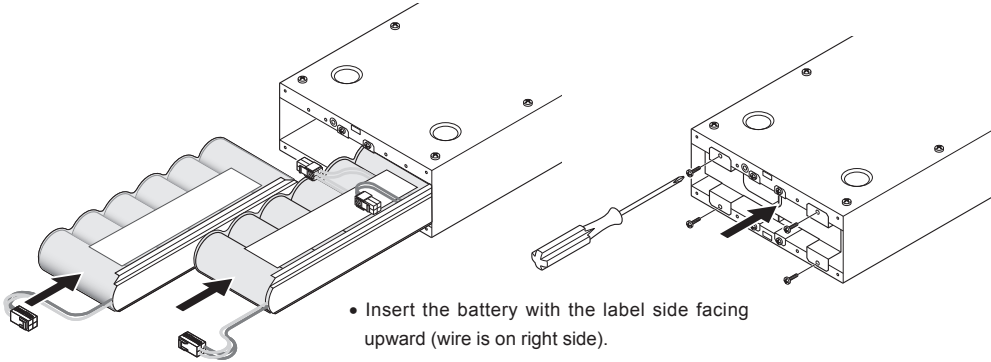

- Insert the battery with the label side facing upward (wire is on right side).

(5) Connect the connectors.

- Make sure the connector locks are firmly secured.



(6) Attach the front panel.

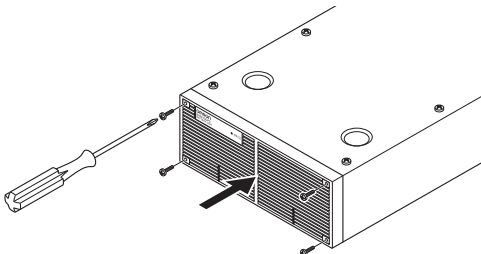

<After replacing the battery during operation...>

Press the beep stop/test button for 10 sec. to perform a self-diagnostic test. Normal operation resumes after the 10-second test. If the beep sounds, it will stop the first time the switch is pressed. Press the switch again to start the test.

If the battery replacement indicator and beep were activated before replacing the battery, the indicator and beep stop after the test is complete, and normal operation resumes.

<After replacing the battery with operation stopped...>

Connect the AC input plug to a wall outlet (commercial power), and turn ON the power switch of the UPS. When operation starts, the self-diagnostic test is automatically performed. Normal operation resumes after the 10-second test.

Also, if using the UPS monitoring software included with the UPS, keep a record of the software usage start date.

◆ Notes ◆

This unit uses a lead acid battery.

- A Lead acid batteries are a valuable recyclable resource. Please recycle.
- For information about recycling, please contact our Electronic Systems & Equipments repair center.

4. Replacing the battery unit

The UPS (BH60PCW/BH100PCW) battery unit (BHM60PC/BHM100PC) can be replaced without stopping output when used in the ways described below.

- Replacement without stopping output can be performed in the following case, only when the bypass function is available.

When replacement is being performed, the unit switches to bypass output.

(1) Input/output synchronization operation

(Normal usage, where output frequency is synchronized with input frequency before output)

Battery connection	Available
SW8 Cold start	OFF
Setting switch selection SW9 Synchronized/ Non-synchronized selection	OFF
SW10 50/Hz selection	OFF/ON

Bypass switch	ON
---------------	----

● Replacement procedure

With the power supply output switch ON during normal operation (inverter output), you can switch to maintenance mode to perform replacement for the operations described below.

(1) Press and hold the indicator selection switch (on the front panel of the UPS) for 10 seconds.

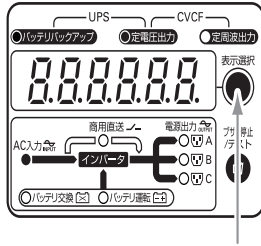

The status indicator shows "REP".



Power supply output switch

- The beep sounds.

(2) The unit switches to bypass mode, enabling the battery unit to be replaced.

 Caution: In this operating condition, the unit will not enter Battery Mode if a power failure occurs.

- Disconnect the connectors of all cables connected to the rear of the battery unit.
- After replacing the battery unit, make sure to reconnect all of the disconnected cables.
- Make sure the battery unit's built-in battery connector (in the front panel) is connected.
- If commercial power is supplied to the battery unit, make sure the "charging" indicator on the battery unit's front panel is illuminated.

(3) When you finish connecting the battery, press and hold the indicator selection switch (on the front panel of the UPS) for 10 seconds.

- Maintenance mode is released and the unit returns to normal inverter operation.
- The status indicator returns to its normal input voltage display (VI ***).



● Battery replacement is complete.

Circuit block diagram

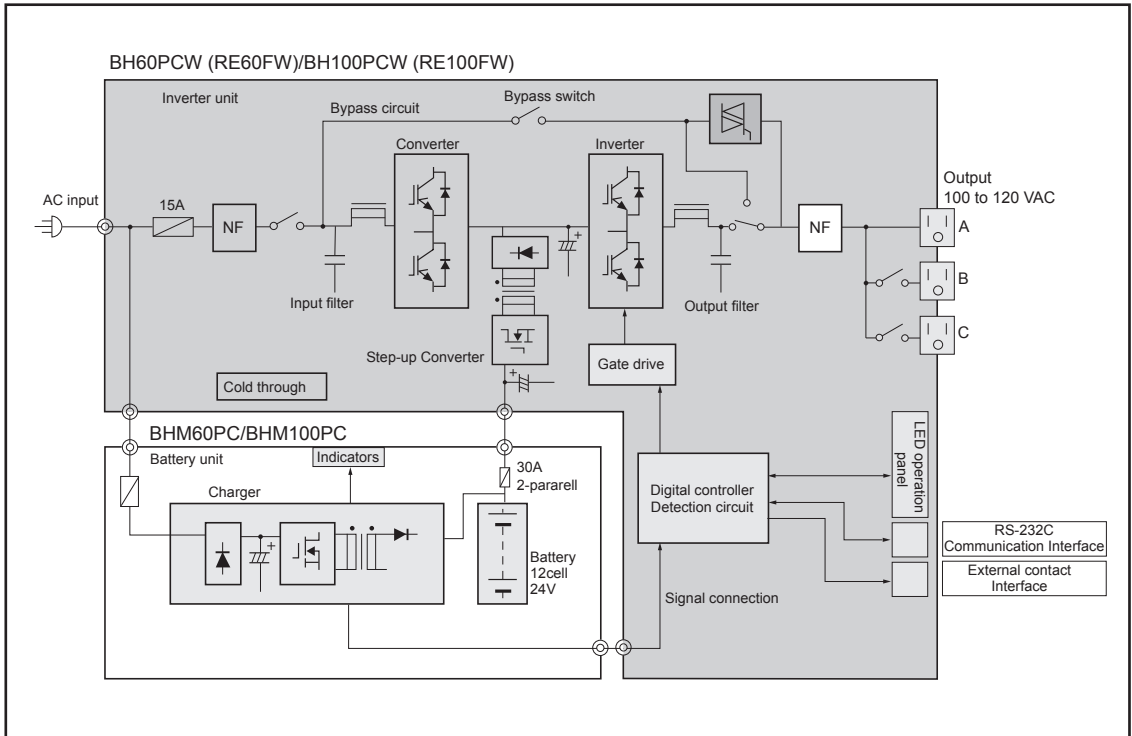

OMRON