

Uninterruptible Power Supply UPS BA75T/BA100T/BA100R Instruction Manual 使用说明书

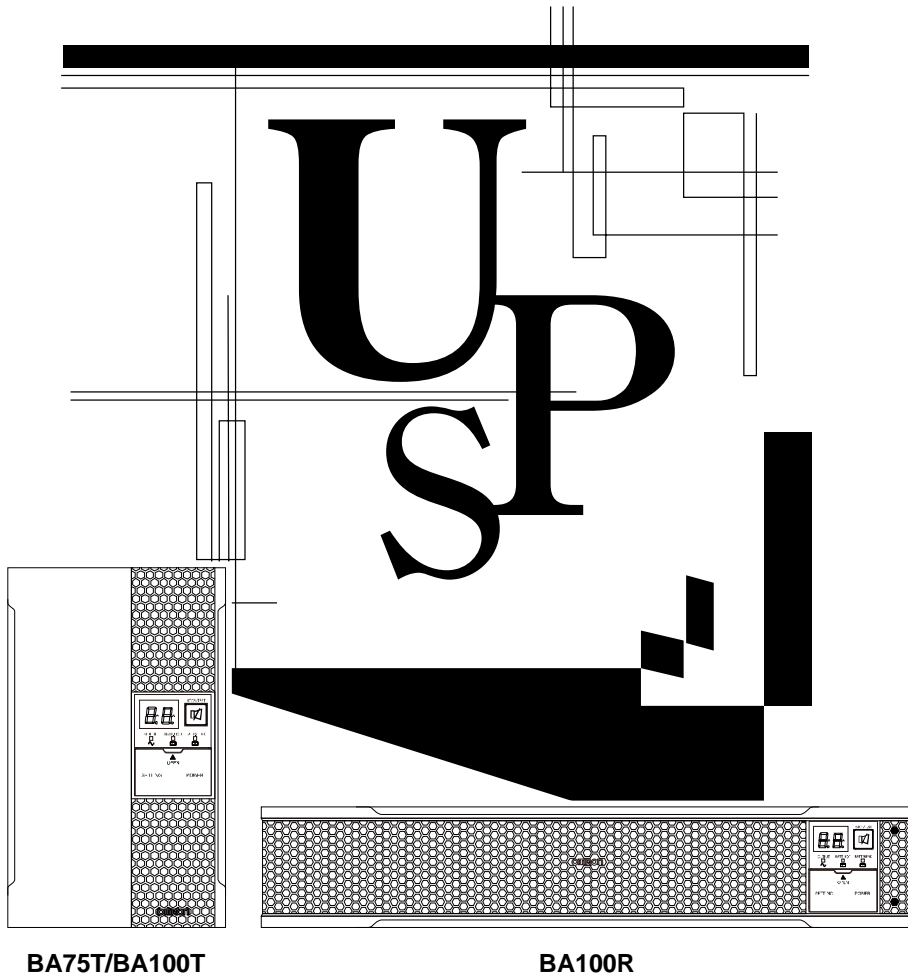

BA75T/BA100T

BA100R

- This manual provides important safety-related information. Thoroughly read and understand this manual before installing and using the product.
- Keep this manual in a convenient location so that you can refer to it whenever necessary.
- The contents of this manual are subject to change without notice.
- The warranty is included with the product.

中文使用说明书请参照“8 Note of Chinese”。

Introduction

Features of this product

Thank you for purchasing Omron's Uninterruptible Power Supply (UPS).

- The UPS protects computers and other devices from power failures, voltage variations, instantaneous voltage drops, and surge voltage such as that caused by lightning (a phenomenon in which extraordinary high voltage occurs instantaneously).
- Under normal conditions, commercial power is converted to direct current, and then it is converted back to a stable sine wave AC power before it is output.
When a commercial power failure is detected, the unit switches to battery supply to provide continuous sine wave output. This is especially suitable for use where power supply conditions are poor (for example, when there are large variations in voltage)
- Output capacity is 750VA/600W for BA75T, 1000VA/800W for BA100T/BA100R.

Notes on the use of the Backup Power Supply

- This product is designed and manufactured for use with FA or OA equipment.
Do not use it when very high reliability and safety are required as listed below.
 - Medical equipment that may cause death directly
 - Applications that may cause injury (applications that directly affect the operation and control of planes, ships, railroads and so on)
 - Applications that are always subjected to vibration such as cars and ships
 - Applications in which a failure of this product may cause significant damage or effect to the society and public (important computer systems, main communication equipment, public transportation systems and so on)
 - Equipment with the same level of importance
- For equipment that greatly affects the safety of people and maintaining public functions, special considerations related to operation, maintenance, and management must be taken such as duplicating the system and emergency power generation facilities.
- Observe the contents of this manual such as the use conditions and environments.
- When you want to use this product for an important system that requires very high reliability, contact us.
- Do not modify/alter this product.

Disclaimers

We are not liable for any damage or secondary damage resulting from the use of our product, including malfunction and failure of equipment, connected devices, or software.

Make sure to read the safety precautions before using the unit.

- In the event you transfer or sell this unit to a third party, please include all of the documentation that came with this unit. This is to ensure that the unit is used in line with the conditions described in the included documentation.
- This manual contains important safety-related information. Please read and understand the contents of the manual before beginning operation.
If you discover any omissions or errors in the manual, please contact the shop of purchase.
- Windows is the registered trademark of Microsoft Corporation in the United States and/or other countries.
- The names of other companies and products mentioned herein are the trademarks or registered trademarks of their respective owners.

©OMRON SOCIAL SOLUTIONS CO.,LTD. 2015-2019 All Rights Reserved

IMPORTANT SAFETY INSTRUCTION

1. SAVE THESE INSTRUCTIONS.

This manual contains important instructions for BA75T/BA100T/BA100R that should be followed when using the UPS and batteries.

2. SYMBOL



This symbol indicates earth ground.



This symbol indicates turning on/off UPS.

3. INTERNAL BATTERY

Internal battery voltage is 24VDC for BA75T/BA100T/BA100R.

4. TEMPERATURE RATING

The maximum ambient temperature of the UPS is 40°C.

5. ENVIRONMENT

The unit is intended for installation in a temperature controlled, indoor area free of conductive contaminants.

Procedure from installation to operation

The procedure from installation to operation is shown below.

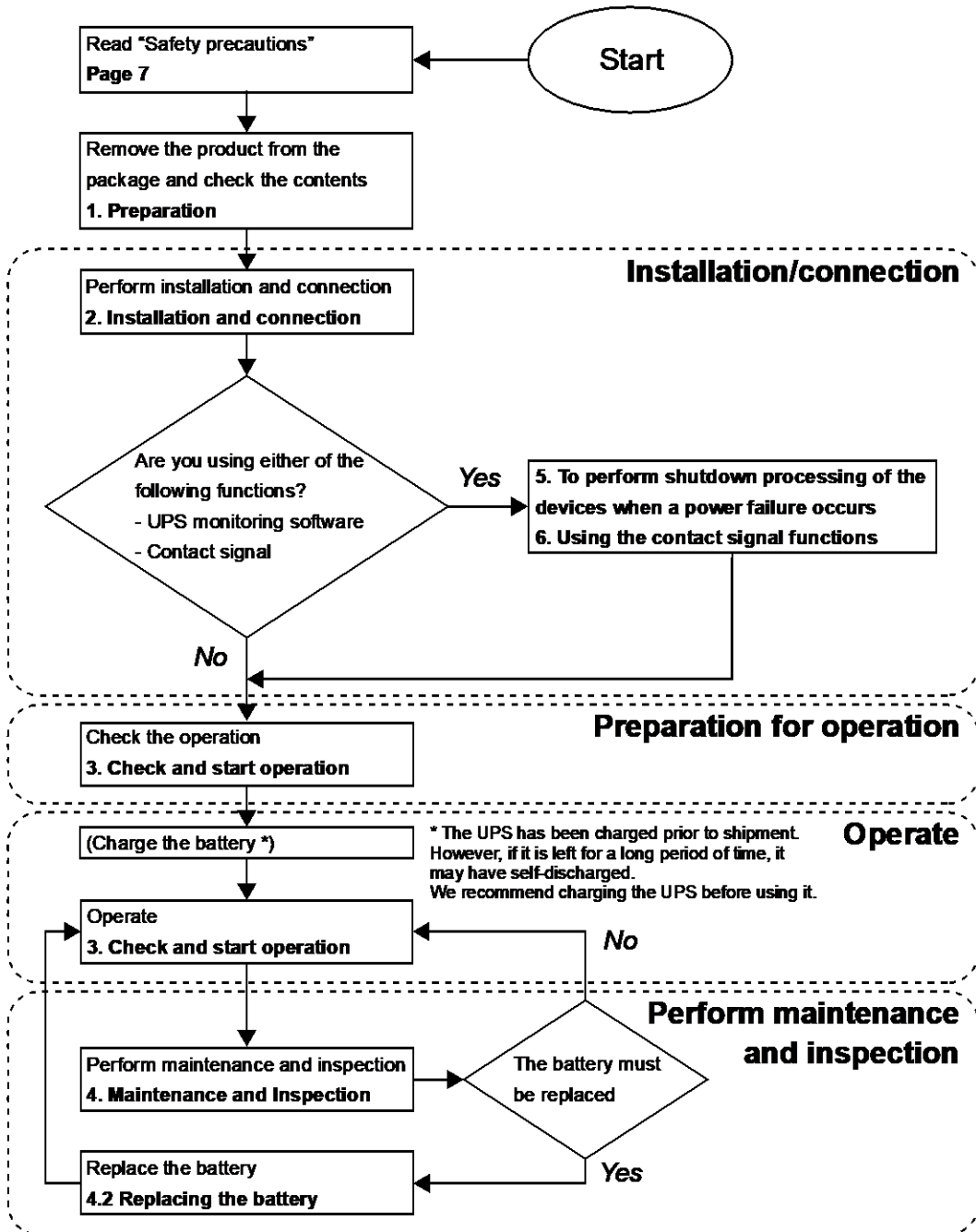

Table of Contents

Introduction	1
Procedure from installation to operation	3
Table of Contents	4
Safety Precautions	7
1 Preparation	16
1-1 Unpacking the product	16
1-2 Checking the contents	16
1-3 Related products	17
1-4 Name of each part	18
1-5 Diagram of the Input/output circuit block	20
2 Installation and connection	21
2-1 Installation	21
2-1-1 Rackmount installation (EIA/JIS 19-inch rack/server rack)	24
2-1-2 Stationary installation	27
2-2 Connecting the equipment	29
2-2-1 Connecting a device to the power supply output	29
2-3 Connecting the AC input	31
2-3-1 Connecting to the input terminal block	31
3 Check and start operation	34
3-1 The name and function for the operation and display	34
3-1-1 Name of each part	34
3-1-2 The meaning of each LED	34
3-1-3 Switch	35
3-1-4 Setting Switch	35
3-1-5 Beep sound	40
3-2 Checking the operation	41
3-3 Start and stop procedures and basic operation	44
3-3-1 Start and stop procedures	44
3-4 Interpreting beeps and displays	46
3-4-1 Displays and beeps in normal operations	46
3-4-2 Displays and beeps while testing	47
3-4-3 Displays and beeps during power failure or AC input error	47

3-4-4	Displays and beeps when there is an equipment failure	48
3-4-5	Display and beep for battery replacement	50
3-5	UPS operation mode settings	51
3-5-1	Settable items and explanations	51
3-5-2	Settings	53
4	Maintenance and Inspection	57
4-1	Checking the battery	57
4-1-1	Battery life expectancy	57
4-1-2	Self-diagnosis test	57
4-1-3	Estimated backup time	58
4-2	Replacing the battery	60
4-2-1	Notification that the battery needs to be replaced	61
4-2-2	Procedure for replacing the battery	62
4-3	Replacing the fan	72
4-3-1	Fan replacement procedure	73
4-4	Cleaning	77
5	To perform shutdown processing of the devices when a power failure occurs	78
5-1	The outline on the UPS monitoring software	78
5-1-1	UPS monitoring software function list	78
5-1-2	The supported OS of the UPS monitoring software	80
5-2	When using the UPS monitoring software	80
5-2-1	What is the PowerAct Pro	80
5-2-2	What is the Simple Shutdown Software	80
5-2-3	How to connect	81
6	Using the contact signal functions	83
6-1	Contact signal functions	83
6-1-1	Type of Output signals	83
6-1-2	Type of Input signals	83
6-1-3	Contact signal port (female D-SUB 9 pin)	84
6-1-4	Remote ON/OFF port	84
6-1-5	Contact Signal ratings	84
6-1-6	Contact Signal circuit	84
6-1-7	Example of the use of the Contact Signal circuit	85
6-1-8	Precautions and notes for the use of the Contact Signal	85



Table of Contents

7	Troubleshooting.....	86
8	Note of Chinese.....	87
9	References.....	97
9-1	Specifications.....	97
9-2	Dimensions.....	98
9-3	Battery life.....	103
9-4	China RoHS Information.....	104

Safety Precautions

Safety precautions Important information for safe operation is described. Be sure to read it before installation and start of use.

- The safety symbols and their meaning used in this manual are as follows:

 Warning	Misuse may cause death or serious injury.
 Caution	Misuse may cause injury or property damage.

* Property damage means damage to houses/household effects, livestock, and pets.

 : Indicates prohibition. For example,  indicates that disassembly is prohibited.

 : Indicates obligation. For example,  indicates that grounding is necessary.

Note that events categorized as a caution required matter also may cause more serious results under certain conditions.

Warning (for use of this product)

Do not use this unit when very high reliability and safety are required as listed below. This unit is designed and manufactured for use with FA or OA equipment such as personal computers.

- Medical equipment or system that may cause death directly.
- Applications that directly affect the safety of people (For example, the operation and control of cars and elevators).
- Applications in which a failure of the unit may cause significant damage to the society and public. (For example, essential computer systems and main communication equipment.)
- Applications with the same level of importance.



This is a category C2 UPS product. In a residential environment, this product may cause radio interference, in which case the user may be required to take additional measures.

This is a Class A product based on the standard of the VCCI Council. If this equipment is used in a domestic environment, radio interference may occur, in which case, the user may be required to take corrective actions.

⚠ Caution (for installation and connection)

Carry the unit considering its weight and balance, and place it on a stable and robust base.

- Dropping or toppling the unit may cause injury.
- The approximate weight of the unit is 12.5 kg (BA75T/BA100T), 13 kg (BA100R).
- If you drop the unit, stop using it and have it inspected and repaired. For repair, contact us.



Keep plastic package bags out of reach of children.

- Children may suffocate if they place their heads into plastic bags.



Make sure to connect the unit's AC input to a commercial power source with rated input voltage (100 VAC,110VAC,115VAC,120VAC) and 50/60 Hz frequency.

- Connecting to a commercial power source with a different rated input voltage or frequency may result in a fire.
- The unit may fail.



When an abnormality (unusual sound or smell) occurs, turn OFF the unit's "Power" switch to stop the output, and stop the supply of commercial power. The socket-outlet shall be installed near the equipment and shall be easily accessible.

- When performing maintenance on the connected devices, follow the above instructions to ensure safety.



Do not connect devices such as dryers, some solenoid valves, etc., which have a half-wave rectifier that allows only half-cycle AC power to flow through.

- Overcurrent may damage the UPS.



When installing the input cable, make sure to perform the connection as specified.

- When connecting a cable to the terminal block, use a cable that complies with the input current specification of the UPS. Failure to do so may result in electric shock or ground fault.



Provide secure grounding.

- Connect the terminal to a commercial power source and ground it. A failure or leak that occurs when the unit is not properly grounded may result in electric shock.



Do not disassemble, repair, or modify the unit.

- Doing so may cause an electric shock or a fire.



Do not install the unit in other than specified orientations.

- Dropping or toppling the unit may cause injury.
- If you install the unit in an orientation other than specified, the unit cannot be protected from a battery fluid leakage.



Do not use the unit where the maximum temperature exceeds 40°C.

- The battery deteriorates rapidly.
- Doing so may cause a failure or malfunction of the unit.



Caution (for installation and connection)

Do not exceed the ranges specified for environmental conditions during use/storage.

Do not install or store the unit in the places listed below.

- Do not store in places where the humidity is lower than 10% or higher than 90%.
- Do not use the unit in places where the ambient temperature is lower than 0°C or higher than 40°C. (With no condensation)
- Do not use in places where the humidity is lower than 25% or higher than 85%
- Do not install/store the unit in closed places such as cabinets with no clearance, places where there is flammable or corrosive gas, places with large amounts of dust, places exposed to direct sunlight, places exposed to shock or vibration, salty or wet places, or outdoors.
- Installation or storing the unit in such a place may cause a fire.



When you use plug strip and other plugs to connect additional devices, do not connect devices that exceed the current capacity of the available plugs.

- The current protection of the unit may operate, which may stop the output.
- The wiring of the plug strip heats up, which may cause a fire.



Do not pinch or sharply bend the cable.

Do not fold or knot the cable.

- Doing so may cause the cable to be damaged or heated, which may cause an electric shock or a fire.
- If the cable is damaged, stop using the unit and have the cable repaired.
- For repair, contact us.



All of the included accessories are designed to be used with the unit. Do not use the accessories with other devices.

- Doing so may compromise the safety of devices.



Do not block the air vents (front, rear, and sides).

- Doing so will cause the internal temperature to rise, which may cause the unit to fail and the battery to deteriorate.
- Leave at least 5 cm of space between the vent and the wall.



When installing the unit on a rack, place it on the lower shelf.

- Injury may result if the unit falls.



Make sure to use the mounting screws included with the brackets.

- Mounting screws other than those included may not be strong enough to support the unit, causing it to fall.
- If you attach the case using long screws other than those included with the product, you may damage the internal parts of the unit.



Caution (for use)

Do not allow the unit to come in contact with water.

If you drop the unit, stop using it.

- Doing so may cause an electric shock or a fire.
- If the unit becomes wet or is dropped, immediately stop using it, disconnect the AC input from the wall outlet (commercial power source) and have it inspected and repaired.
- For repair, contact us.



When the battery is dead, replace it immediately or stop using the unit.

- Continuing the use of it may cause fire or electric shock due to liquid leaks.

Ambient temperature	Expected life
40°C	2 years
30°C	4 years
25°C	5 years

* The values in the table are the expected life under standard use conditions and are not guaranteed.



Using a dry cloth, periodically wipe the dust from the input terminal block and power supply output receptacles.

- Accumulated dust may cause a fire.
- Before wiping off dust, stop all connected devices and the unit, and stop the supply of commercial power.



Do not use the unit in a closed place and do not cover the unit.

- Doing so may cause abnormal heating or a fire.
- Depending on the operating environment, hydrogen gas may be generated from the battery, resulting in a rupture or explosion. Ventilate the area around the unit.



If you notice an abnormal sound or smell, smoke, or leaking fluid, immediately turn OFF the unit's "Power" switch and stop the supply of commercial power.

- Using the unit under such conditions may cause a fire.
- If you notice such a condition, stop using the unit and contact us for inspection and repairs.
- A readily accessible disconnect device shall be incorporated external to the equipment.



If fluid (dilute sulfuric acid) leaks from the interior, do not touch the fluid.

- Doing so may cause blindness or burns.
- If the fluid contacts your eyes or skin, wash it out with lots of clean water and consult your doctor.



Do not place any objects on the unit, and do not drop heavy objects onto the unit.

- Doing so may cause distortion/damage to the case or a failure of the internal circuit, which may cause a fire.



Caution (for use)

The unit is equipped with a bypass circuit which is able to supply electric power to connected devices even when the inner control circuit is broken down by defects or malfunctions.

If you want to stop the output, either stop the source of commercial power.

- Output is continuing even when all indicators of the front panel are off.
- Output ON/OFF cannot be controlled with the “Power” switch on the front panel.



Do not sit or stand on top of the product, use it as a step ladder, or lean against it.

- Doing so may cause the unit to fail or to fall over and result in injury.



Caution (for maintenance)

When maintaining the connected equipment, turn OFF the unit’s “Power” switch to stop the output, and stop the supply of commercial power.

- Even if commercial power to the UPS is stopped while it is in operation, the power output of his unit does not stop and power is supplied from the receptacle.



Do not disassemble, repair, or modify the unit.

- Doing so may cause an electric shock or a fire.



If fluid (dilute sulfuric acid) leaks from the interior, do not touch the fluid.

- Doing so may cause blindness or burns.
- If the fluid contacts your eyes or skin, wash it out with lots of clean water and consult your doctor.



Do not throw the unit into fire.

- The lead battery in the unit may explode, or leak dilute sulfuric acid.



Do not insert metal objects into the power supply output receptacle of the UPS.

- Doing so may result in electric shock.



Do not insert metal objects into the battery connectors.

Do not short between the connector terminals.

- Doing so may result in electric shock.



Caution (for battery replacement)

Perform replacement on a stable and flat place.

- Handle the battery carefully so that you do not drop it.
- Risk of injury due to falling, or burns due to fluid leakage (dilute sulfuric acid).



⚠ Caution (for battery replacement)

Use a specified battery for replacement.

- Not doing so may cause a fire.

- Battery pack for:

Product model: BAB100R: Battery pack for BA100R

BAB100T: Battery pack for BA75T/BA100T



Do not replace the battery in a place where there is flammable gas.

- Spark may occur when connecting the battery, which may cause an explosion or fire.



If fluid (dilute sulfuric acid) leaks from the battery, do not touch the fluid..

- Doing so may cause blindness or burns.
- If the fluid contacts your eyes or skin, wash it out with lots of clean water and consult your doctor.



Do not disassemble or modify the battery.

- Doing so could cause dilute sulfuric acid leak, which could cause blindness and burns.



Do not drop the battery and do not expose it to strong impact.

- Dilute sulfuric acid may leak.



Do not short the battery with metal objects.

- Doing so could cause an electric shock, fire or burn.
- Some electrical energy still remains inside the spent battery.



Do not dispose of batteries in a fire.

- The batteries may explode.
- Dispose of used batteries according to the instructions.



Do not use a new battery and an old battery at the same time.

- Dilute sulfuric acid may leak.
- A battery can present a risk of electrical shock and high short circuit current.
- Contact with any part of a grounded battery can result in electrical shock.
- The following precautions should be observed when working on batteries:
 - Remove watches, rings, or other metal objects.
 - Use tools with insulated handles.
 - Wear rubber gloves and boots.
 - Do not lay tools or metal parts on top of batteries.
 - Disconnect charging source prior to connecting or disconnecting battery terminals.
 - Remove battery grounds during installation and maintenance to reduce likelihood of shock. Remove the connection from ground if any part of the battery is determined to be grounded.
- Servicing of batteries should be performed or supervised by personnel knowledgeable of batteries and the required precautions.
Keep unauthorized personnel away from batteries.



ATTENTION

Ne pas ouvrir ni détériorer les batteries.

Les fuites d'électrolyte sont dangereuses pour la peau et les yeux.

Protéger les batteries du feu. Risque d'explosion des batteries.

Utilisez les batteries conformément aux instructions.

Les batteries peuvent présenter un risque de choc électrique avec un fort courant de court circuit.

Les précautions suivantes doivent être suivies lors de l'intervention sur les batteries :

- a : Retirer les montres, bagues et autres objets en métal
 - b : Utilisez des outils à manche isolé
 - c : Utilisez des gants et des chaussures isolants
 - d : Ne pas laisser des outils ou des objets métalliques proches des batteries
 - e : Déconnecter le chargeur avant de connecter ou de déconnecter les batteries
 - f : Déterminer si la pile est mise à la terre. Si elle est mise à la terre, effectuer la déconnexion. Le contact avec une pile mise à la terre peut créer un choc électrique. Ceci sera réduit si cette mise à la terre est supprimée pendant l'installation et la maintenance.
-

Notes

■ Before using

Charge the battery soon after purchasing the unit.

- If you do not use the unit for a long time after the purchase, the battery may deteriorate and the battery may become unusable.
- The battery can be charged once the AC input is connected to commercial power.

When moving the unit from a cold place to a warm place, leave it for several hours before using it.

- If the unit is promptly turned ON after being moved to a warmer place, condensation may form inside the unit and cause it to fail.

Take measures for handling unforeseen accidents, such as data backup and system redundancy.

- The output may stop when there is failure in the UPS.

■ Connecting

Do not connect a page printer (such as a laser printer) to the unit.

- The unit repeatedly and frequently switches between Commercial Power Mode and Battery Mode, which may shorten the life of the battery.
- The page printer has a large peak current, so an excess of the connection capacity or a power failure due to instantaneous voltage drop may be detected.

If this unit is used for an inductive device such as a coil, transformer or motor, check the operation beforehand.

- With some types of devices, the effect of inrush current may cause this unit to stop operating properly.

Check system operation beforehand if the unit is used in combination with a device whose power supply voltage and frequency fluctuate widely, such as a generator.

- If the generator's output voltage/frequency falls out of the unit's input voltage/frequency range, the unit will enter Battery Mode.

Do not short the output lines of the unit to each other, and do not short the output lines to the ground.

- The unit may fail.

In the event you transfer or sell this unit to a third party, please include all of the documentation that came with the unit. This is to ensure that the unit is used in line with the conditions described in the included documentation.

- This manual contains important safety-related information. Please read and understand the contents of the manual before beginning operation. If this manual is misplaced, download the manual from our website.

■ Using

Before stopping the commercial power to the unit, turn OFF the “Power” switch of the unit.

- The unit enters Battery Mode when commercial power is stopped.
-

Do not use for an application that frequently requires Battery Mode.

- The battery will deteriorate and fail to maintain the specified backup time.
-

Do not connect the AC input terminal of the unit to its Power Supply Output terminal during the Battery Mode.

- The unit may fail.
-

This unit uses lead acid batteries.

- Which are a valuable recyclable resource. Please recycle.
-

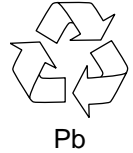

Before performing a withstand voltage test or insulation resistance test, remove the input surge protection GND screw from the back of the unit. When in use, make sure the input surge protection GND screw is securely fastened.

- Performing the withstand voltage test with the ground wire connected may damage the surge absorption element built into the power supply input circuit.
-

■ Storing

Storing the battery in UPS, charge for at 4 hours, then turn off the "Power" switch of the unit.

Recharge the battery for at least 4 hours every 6 months when the storage temperature is 25°C or less, or every 2 months when the storage temperature is 40°C or less.

- The battery self-discharges even when it not being used, and it goes into overdischarge state if it is left for a long period of time. The backup time may become shorter or the battery may become unusable.
 - We recommend keeping the temperature 25°C or less when storing the unit for long periods of time.
 - Turn OFF the unit's "Power" switch when storing it.
-

Do not install or store the unit in a place exposed to direct sunlight.

- The rise of temperature may cause the built-in battery to deteriorate rapidly and become unusable.
-

1 Preparation

1-1 Unpacking the product

1 Preparation

1-1 Unpacking the product

Caution (for installation and connection)

The approximate weight of the unit is 12.5 kg (BA75T/BA100T), 13 kg (BA100R). Note the weight when unpacking and transporting the unit.



- Dropping may cause injury.

Open the package box and take out the UPS and accessories.

1-2 Checking the contents

Check whether all the package contents are included and there is no damage found on their appearance. If you should notice defects or anything wrong, contact us; OMRON Electronic Systems & Equipments Customer Support Center.

	BA75T	BA100T	BA100R
Precautions (Japanese/English/Chinese/French)	1	1	1
Rubber feet	-	-	4 per set
Connection cable (RS232C)	1	1	1
Remote ON/OFF connector	1	1	1
Registration post card	1	1	1
Input terminal block cover	1	1	1
Serial number label	1	1	1
Battery replacement date label	1	1	1
Label (How to determine operating status)	1	1	1
Product warranty (Japanese)	1	1	1
Product warranty (Chinese)	1	1	1

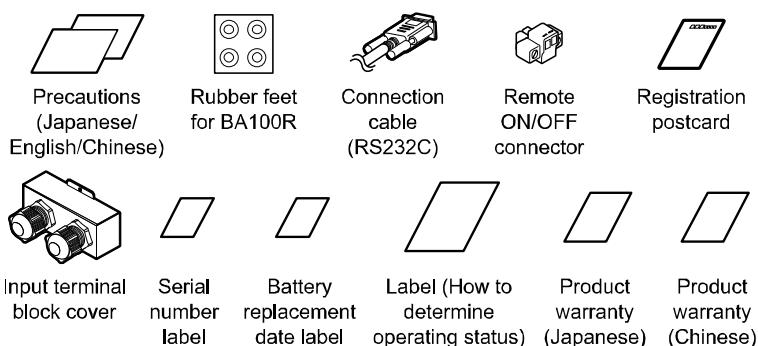

1-3 Related products

Description	Model Number
Replacement battery pack for BA75T/BA100T	BAB100T *1
Replacement battery pack for BA100R	BAB100R *1
Input power cable	BAX15NP
Replacement fan	BAF100R
Support angles compatible with EIA/JIS 19-inch racks	BAP100RS *2
Upright stand for BA100R	BAP100R
Upright stand for BA75T/BA100T	BAP100T
CD-ROM "PowerAct Pro" UPS monitoring software, "Simple Shutdown Software", and UPS service driver are included.	PA01

- *1 Battery pack of BAB100T and BAB100R information:
a) 2 pcs of CSB/HRL1234 (FR)
b) Nominal voltage of total battery string: 24VDC
c) Nominal capacity of total battery string: 34W
- *2 The length is from 487 to 891mm.

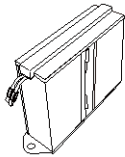

Replacement
battery pack for
BA75T/BA100T

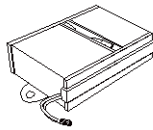

Replacement
battery pack
for BA100R

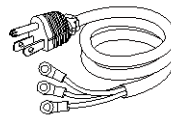

Input power cable

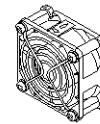

Replacement
fan

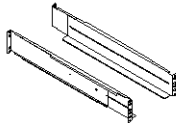

Support angles
compatible with
EIA/JIS 19-inch racks

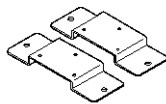

Upright stand
for BA100R

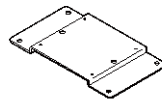

Upright stand
for
BA75T/BA100T



CD-ROM

1 Preparation

1-4 Name of each part

1-4 Name of each part

This section describes the name of each part of the UPS.

For information on the function of each part, refer to “2 Installation and connection” and “3 Check and start operation” that provides the details.

● Front view <BA75T/BA100T>

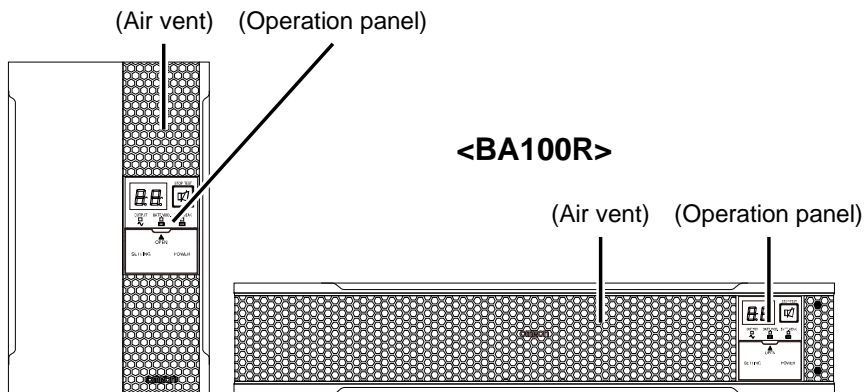

<Enlarged view of the operation panel>

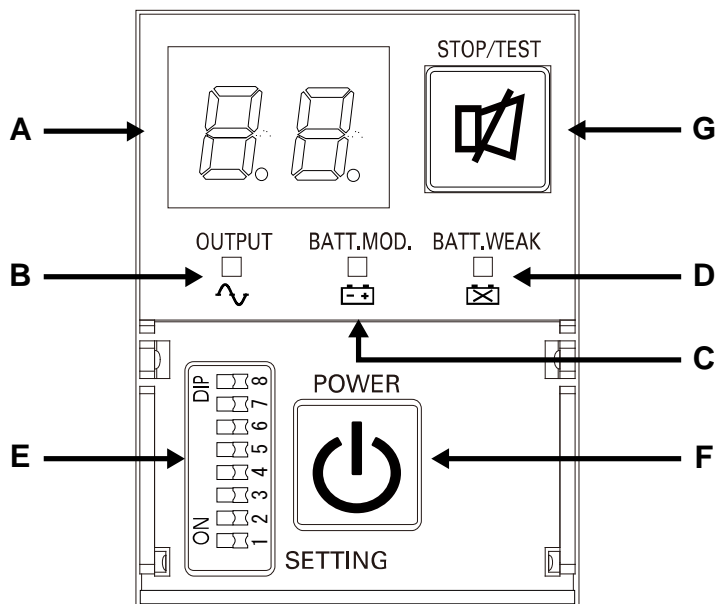

- A: Status indicator
- B: “Power supply output” LED
- C: “Battery mode” LED
- D: “Battery replacement” LED
- E: “Setting switch”
- F: “Power” switch
- G: “Buzzer Pause/Test” switch

● Rear view

<BA75T/BA100T>

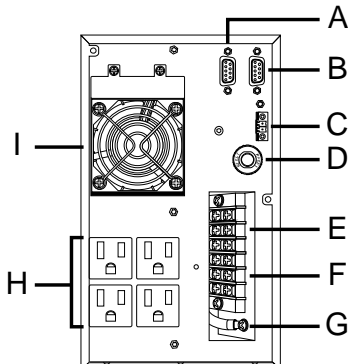

- A: RS232C port
- B: Contact signal port
- C: Remote ON/OFF port
- D: Input protection
- E: AC input terminal block
- F: AC output terminal block
- G: Input surge protection GND
- H: Power supply output receptacles
(Backup is performed during power failure.)
- I: Cooling fan (air vent)

<BA100R>

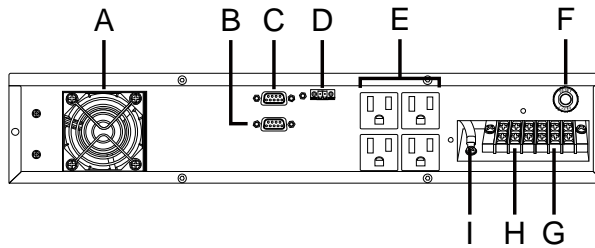

- A: Cooling fan (air vent)
- B: RS232C port
- C: Contact signal port
- D: Remote ON/OFF port
- E: Power supply output receptacles
(Backup is performed during power failure.)
- F: Input protection
- G: AC input terminal block
- H: AC output terminal block
- I: Input surge protection GND

1 Preparation

1-5 Diagram of the Input/output circuit block

1-5 Diagram of the Input/output circuit block

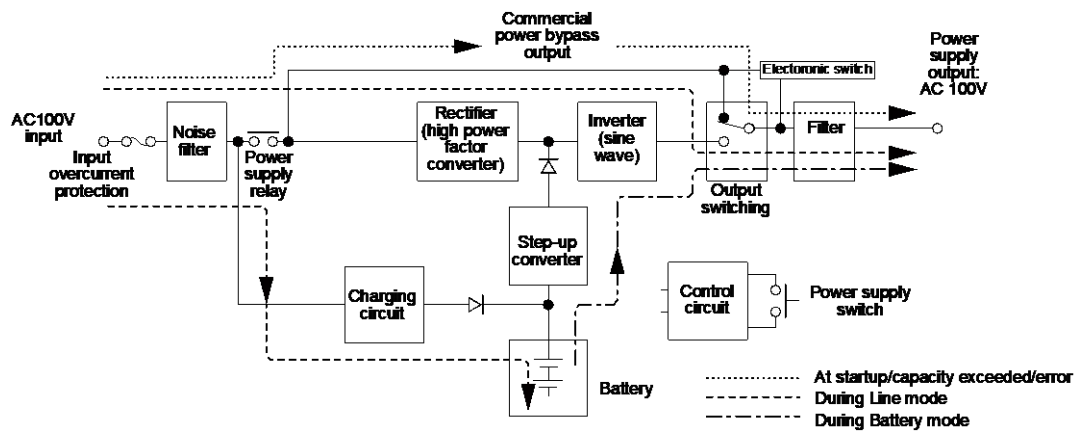

2 Installation and connection

2-1 Installation

Install the UPS.

For cautions when installing the UPS, refer to "Caution (for installation and connection)" shown in the "Safety precautions" of the beginning of this manual.

The UPS permits the following installing methods. Choose the one best suited for the environment.

Notes

- Before installing this device, make a record of the serial number of this device. The product serial number is required when contacting us about the device. The serial number (S/N) is inscribed on the bottom left side of the rear panel. The product serial number is inscribed on the bottom left side of the rear panel. The product serial number label is also included.
- Allow sufficient space at the back for the AC input cables of the UPS unit and connected devices.

<BA75T/BA100T>

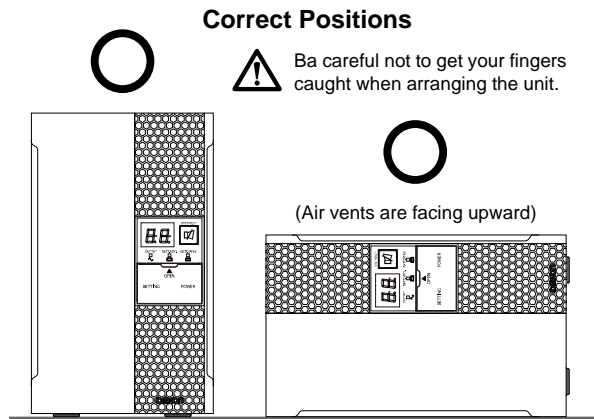

2 Installation and connection

2-1 Installation

Incorrect Positions

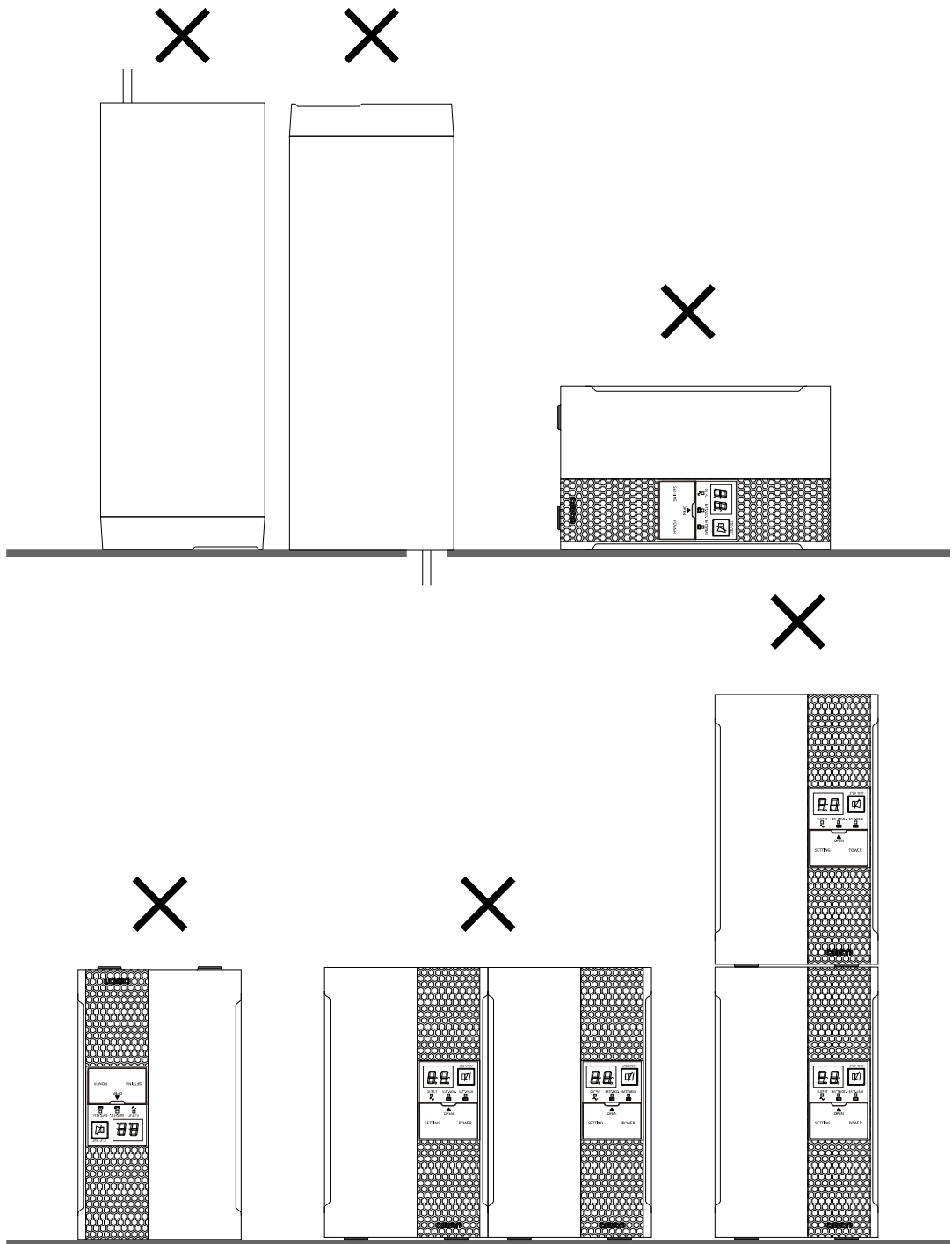

<BA100R>

Correct Positions



Ba careful not to get your fingers caught when arranging the unit.

Note: Upright stand for BA100R, BAP100R, is necessary for this position.

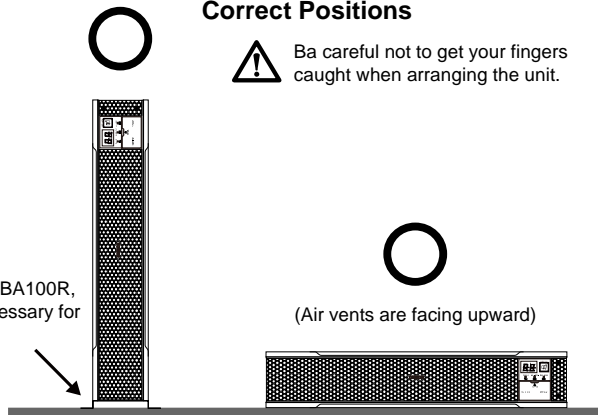

Incorrect Positions

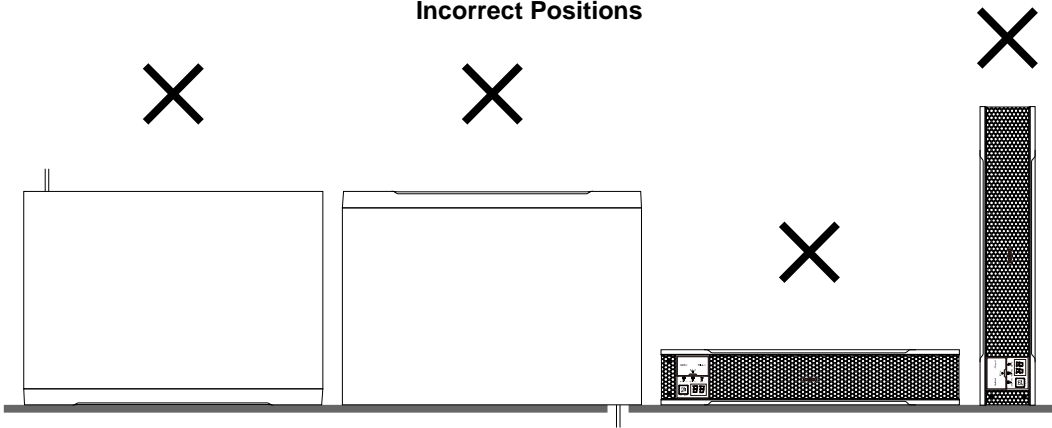

2-1-1 Rackmount installation (EIA/JIS 19-inch rack/server rack)

Caution

When performing rack installation, ensure that the UPS is supported and stabilized by using both the support angles and the table clamps that were rated.

- When installing on a rack, make sure that the UPS is supported by the each unit individually.
- When installing on a rack, make sure to use the support angles and table clamps included with the product. Without the support angles, the front clamp alone cannot support the weight of the UPS.
- The mass of each unit: BA100R: Approx. 13 kg.



In a case where the UPS is to be mounted on a rack, place it on the lower part of the rack.

- Dropping it may result in injury.



Be sure to use the supplied mounting screws.

- Use of long screws other than those supplied for case mounting may damage inside the unit.
- When installing on a rack, make sure to use the support angles and table clamps included with the product. Without the support angles, the front clamp alone cannot support the weight of the UPS.
- Screws other than those supplied may not be strong enough to support the UPS, causing it to fall.



■ Items included in the 19-inch rack support angle mounting bracket set (BAP100RS)

Rack rail (front) L.....	1
Rack rail (front) R.....	1
Rack rail (rear).....	2
Ear brackets.....	2
Rail length fixing screws (M4 x 8).....	4
Ear bracket mounting flat-head screws (M3 x 6).....	8
EIA/JIS rack fixing screws (M5 x 16).....	10
JIS rack fixing flat-head screws (M5 x 14).....	2
EIA rack fixing nuts (M5).....	10

■ Rack mounting procedure

1. Insert the 4 included rail length fixing screws (M4) and half-tighten them to hold the front and rear rack rails in place. (1 There are 2 types of the front rack rail; left (L) and right (R). The rear rack rails are same.

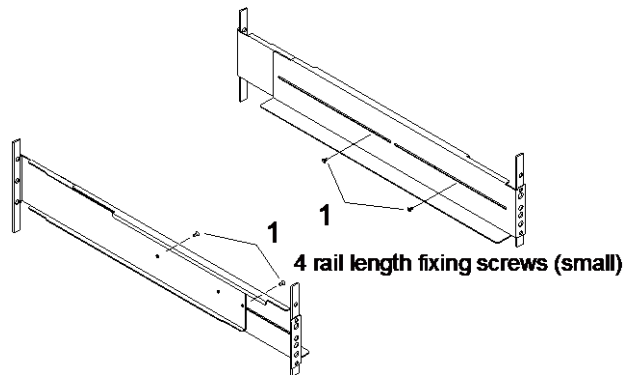

2. Adjust the length of support angles to suit the server rack, and then securely tighten the screws that were half-tightened in step 1. (2)
3. For EIA standard-compliant installation, use the 8 included EIA rack fixing nuts (M5) and 8 EIA/JIS rack fixing screws (M5) to securely fasten the front (the side displaying "L" or "R") and the back of the support angles to the server rack. (3 The screw holes are located at the top and bottom for both front and rear.

For JIS standards, use a total of 6 included screws to fix the rack; 1 JIS rack fixing flat-head screw (M5) at a front position of the each of right and left support angles, 2 EIA/JIS rack fixing screws (M5) at 2 rear positions. (3 The screw hole position for the front is at the second screw hole from the top, the rear is at the second screw hole from the bottom.

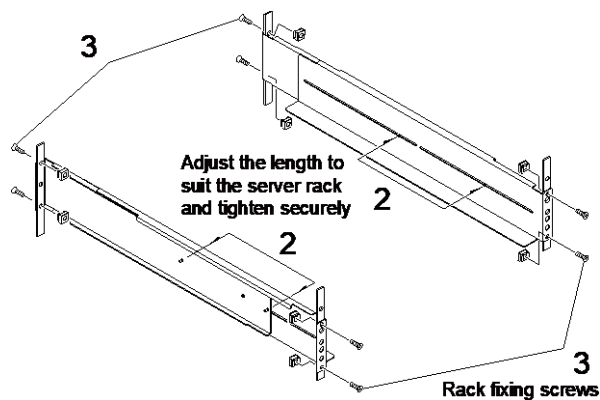

2 Installation and connection

2-1 Installation

4. Use the 8 included ear bracket mounting flat-head screws (2 sets of 4 screws) to securely fasten the ear brackets to the left and right sides of the UPS. (4)

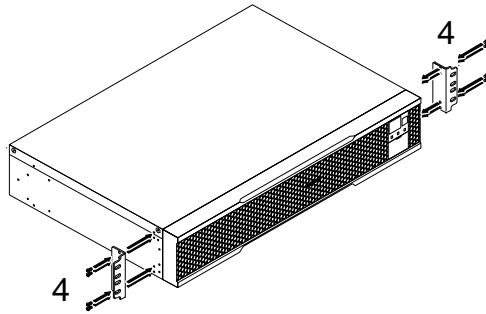

- * The support angles cannot be attached to special EIA/JIS racks.

5. Place the UPS on the support angles and push it completely into the rack (5, and use the 2 included EIA/JIS rack fixing screws (M5) to securely fasten the ear brackets to the server rack. (6)

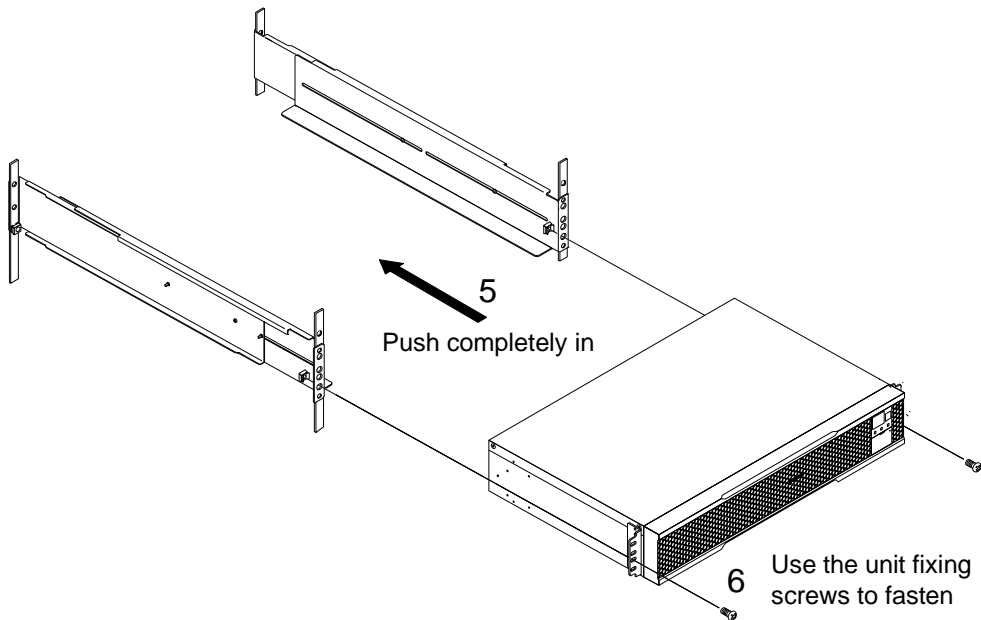

- * Be sure to use the support angles.

2-1-2 Stationary installation

Perform installation only as shown in the diagrams below.

■ BA100R

● Horizontal installation

Attach the included rubber feet for horizontal installation and position the unit horizontally. For stationary horizontal installation, make sure that this product does not slide or fall.

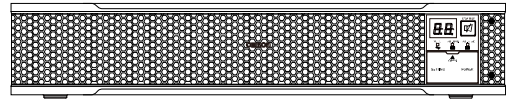

● Upright installation

Use the upright stands (2) and M3 flat-head screws (6) included with the rated product.

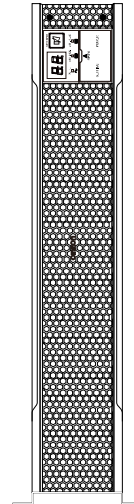
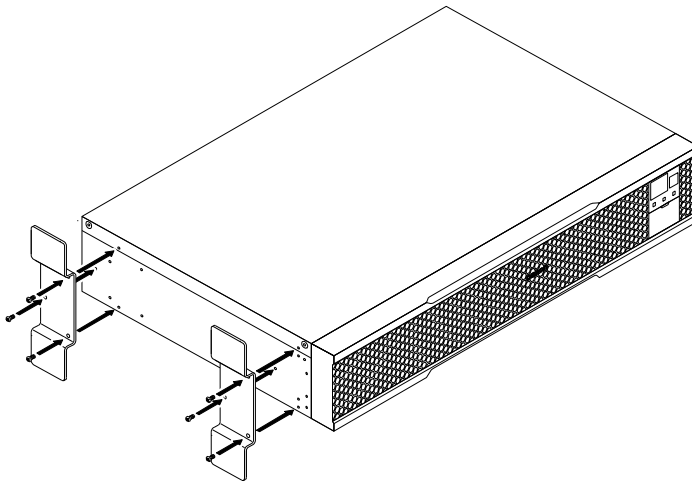

2 Installation and connection

2-1 Installation

■ BA75T/BA100T

● Upright installation

Use the upright stands (1) and M3 flat-head screws (4) included with the rated product, when you want to fix it.

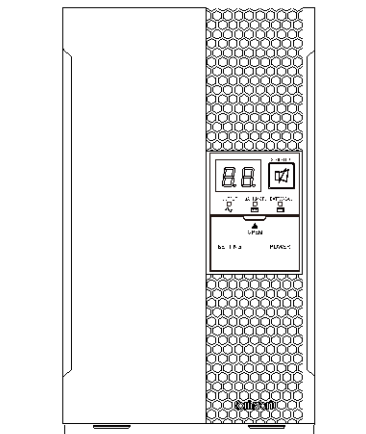
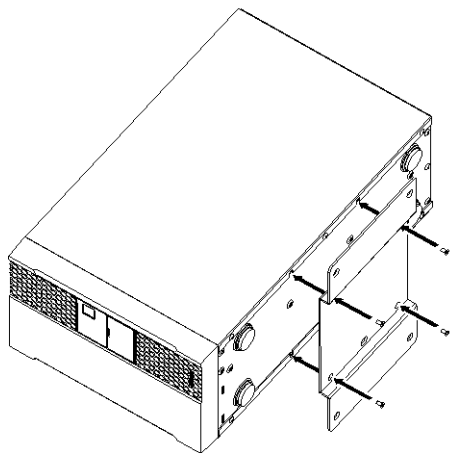

2-2 Connecting the equipment

Caution (for connection)

Do not connect devices, rated voltage is not 100-120VAC.

- The rated output voltage of this device is 100-120VAC.
- Overcurrent may damage the connected devices.



2-2-1 Connecting a device to the power supply output

For cautions when connecting the UPS, refer to “Caution (for installation and connection)” shown in the “Safety precautions” of the beginning of this manual.

1. Disconnect the AC Input Plugs of all devices you want to back up such as your PC and modems from a wall outlet (commercial power source).

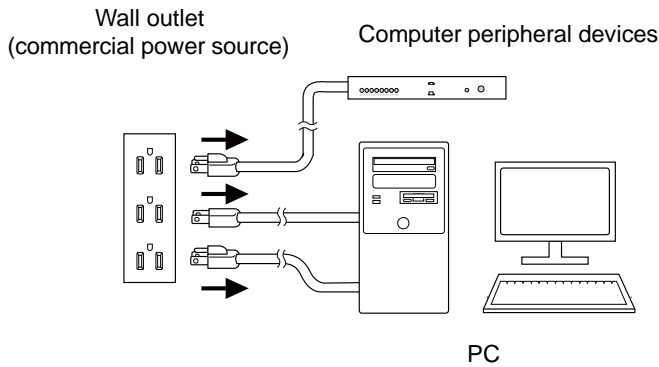

2. Connect devices you want to back up to the Power Supply Output Receptacles of the UPS.

- If you need more output receptacles than those of the UPS, purchase a plug strip and use it for extra output receptacles.

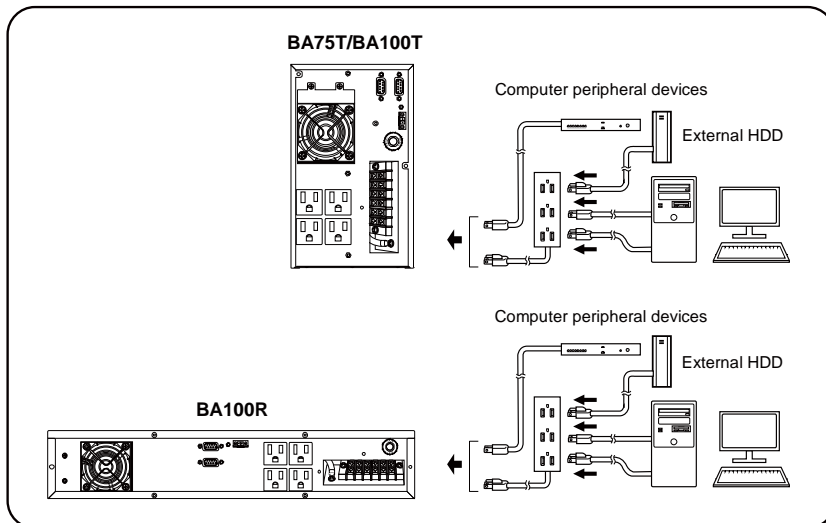

2 Installation and connection

2-2 Connecting the equipment

- When the connected device has a 2-pin AC input plug, it can be connected directly to the power supply output receptacle. When using a 2-pin input plug with a grounding wire, connect the grounding wire to earth in building.
- When you want to use an AC adaptor, connect it to a Power Supply Output Receptacle of the UPS with space enough for the connection.

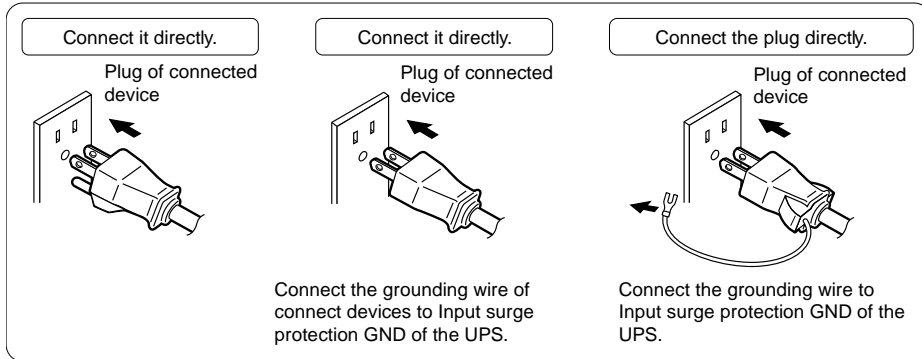

3. When using the UPS monitoring software, use the included RS232C cable. When using the Windows standard UPS service or the contact signal, use the rated connection cable (BUC26) to connect the PC.

- * See also "5 To perform shutdown processing of the devices when a power failure occurs", and "6 Using the contact signal functions"

Note: If you do not use the UPS monitoring software and Contact Signal, this step is not required.

2-3 Connecting the AC input

When installation and connection are complete, connect the unit's AC input to a commercial power source.

⚠ Caution (for connection)

Make sure to connect the AC input of the unit into a wall outlet (commercial power source) with rated input voltage of 100/110/115/120V AC.

- Connecting to a wall outlet (commercial power source) of a different rated voltage may result in fire.
- The unit may fail.



For other cautions when connecting the UPS, refer to "Caution (for installation and connection)" shown in the "Safety precautions" of the beginning of this manual.

2-3-1 Connecting to the input terminal block

⚠ Caution (for installation and connection)

When connecting the AC input directly from a power switchboard, make sure that the wiring work is performed by a qualified electrical engineer (with Type II certification or higher).

- To use the BA100T/BA100R with up to 1000VA/800W, a wiring capacity of 12A or required. To use the BA75T with up to 750VA/600W, a wiring capacity of 10A or required.



Make sure to properly match the AC input terminal. Turn off the external breaker when performing work on the unit's AC input terminals. Be sure to attach the terminal block cover.

- Failure to do so may result in electric shock or ground fault.



Include a breaker (double pole) between the unit and the commercial power, and install the breaker where it is easy to operate.



■ Connection procedure

1. Remove the terminal block cover.
2. Run the wires through the terminal block cover (with cable clamp).

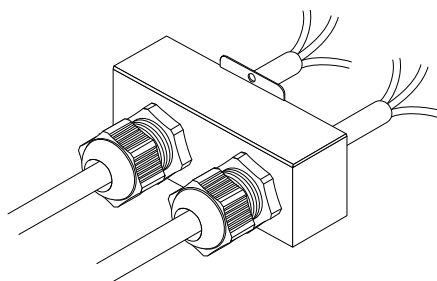

2 Installation and connection

2-3 Connecting the AC input

3. Connect the L line to L. Connect the N line to N, and connect the ground wire to \oplus . Connections to the terminal block shall comply with the standards in Table 1.

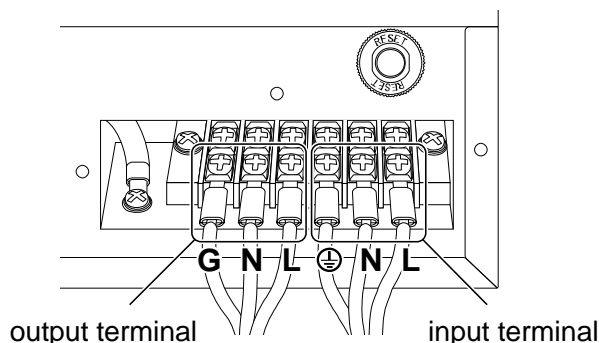
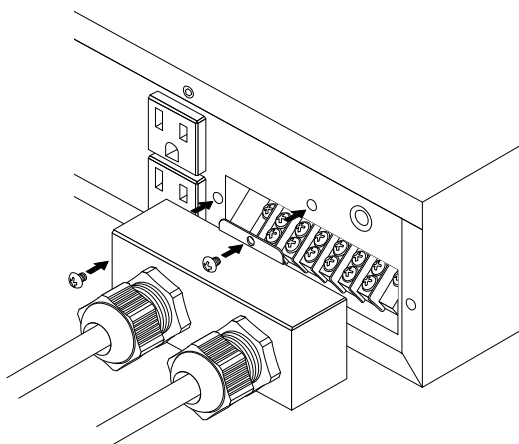

Table 1

Connectable wire type		Flexible cord
Connectable wire size (copper wire only)		2 to 4 mm ² (AWG14 to AWG12)
Recommended cable size		2 mm ² (AWG14)
L, N	Amount of stripped wire	6 to 8 mm
	Tightening torque	1.36 N•m (12 lb-in)
\oplus , G	Tightening torque	1.36 N•m (12 lb-in)

4. Fix the terminal block cover with the screws, and then turn the clamp to stabilize the wires (13mm to 18.5mm).



5. When the installation and connection are complete, connect the input of this unit to a commercial power source such as a power switchboard. When you connect it to a commercial power source, battery charging automatically starts regardless of the ON/OFF state of the "Power" Switch and charging completes within 8 hours.

2 Installation and connection

2-3 Connecting the AC input

100VAC (Example of connection)

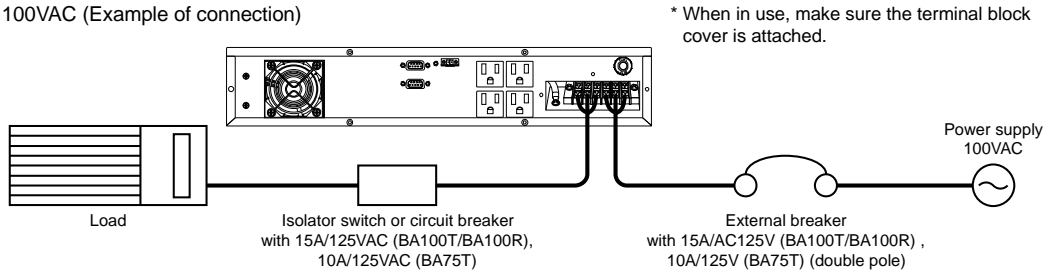

⚠ Caution

To reduce the risk of fire,

- Connect only to a circuit provided with 15A (for BA100T/BA100R), 10A (for BA75T) maximum branch circuit overcurrent protection in accordance with the National Electric Code, ANSI/NFPA 70 and the Canadian Electrical Code, Part I, C22.1
- Disconnect switch shall be provided by others for AC output circuit.



📄 Reference

- The unit was charged before shipment, but it may have self-discharged during shipment, resulting in a reduced backup time. We recommend charging the unit before use.
- You can perform "3-2 Checking the operation" also before charging the battery.

● When you use the input power cable

When you use the input power cable for connecting to a commercial power source, use the input power cable (BAX15NP) included with the rated product. For connecting procedure, refer to "2-3-1 Connecting to the input terminal block".

(When you use the input power cable)

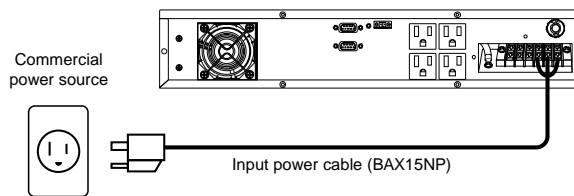

Installation and connection is now complete.

3 Check and start operation

3-1 The name and function for the operation and display

3 Check and start operation

3-1 The name and function for the operation and display

3-1-1 Name of each part

<Enlarged view of the operation panel>

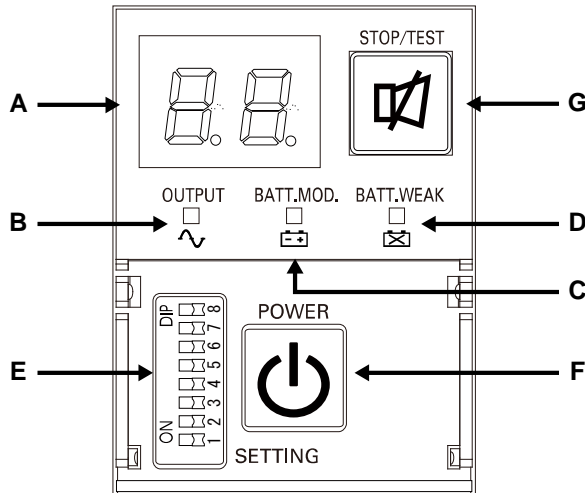



- A: Status indicator
 B: "Power supply output" LED
 C: "Battery mode" LED
 D: "Battery replacement" LED
 E: "Setting switch"
 F: "Power" switch
 G: "Buzzer Pause/Test" switch

3-1-2 The meaning of each LED

Sign of the figure	LED	Color	Name	Status	
				Lit / Blinking	Not lit.
B	OUTPUT 	Green	"Power supply output" LED	(Lit) The power supply output is ON.	The power supply output is OFF.
C	BATT. MOD. 	Orange	"Battery mode" LED	(Lit) Backup is operating. This status is called "Battery Mode".	Backup is not operating.
D	BATT. WEAK 	Red	"Battery replacement" LED	(Blinking) Battery replacement is necessary due to the battery deterioration or the end of battery life.	Battery replacement is not necessary.

3-1-3 Switch

Sign of the figure	Label	Name	Description
F	POWER 	Power switch	ON: Press the "Power" switch of the UPS. The power output from the UPS begins. OFF: Press the "Power" switch of the UPS in ON state, then the power output from the UPS stops. Additional Information: • If the AC input is connected to the commercial power source, then the battery will be charged regardless of the "Power" switch.
G	STOP/TEST 	Buzzer Pause/ Test switch	Stop the beeper by pressing for 0.5 seconds or longer

3-1-4 Setting Switch

After changing the "Setting" switch, follow the procedure described below.

After changing the "Setting" switch, turn off the AC input, wait until the status indicator is completely OFF, and then turn on the AC input.

Use a fine-pointed tool such as a small screwdriver to maneuver the switch's lever.

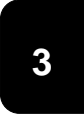

Setting switch function list

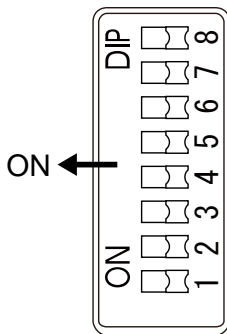

Bit	Function to set	OFF side	ON side	
1	Setting for beeper sound in the event of power failure, etc.	Beeper sounds	Beeper does not sound	
2	Auto startup setting after recovery from power failure	Auto startup is performed	Auto startup is not performed	
3	Setting for whether or not to perform test once every 4 weeks	Test is performed	Test is not performed	
4	Auto startup mode setting by BS signal	Mode A	Mode B	
5	Logic of Remote on/off signal	Short-circuit, Stop	Open-circuit, Stop	
6	---	---	---	
7 8	Synchronous / asynchronous operation setting	Bit 7	Bit 8	Operation Mode
		OFF	OFF	Commercial synchronous operation (ECO mode disabled)
		OFF	ON	Commercial synchronous operation (ECO mode enabled)
		ON	OFF	Asynchronous operation (50 Hz output)
		ON	ON	Asynchronous operation (60 Hz output)

3 Check and start operation

3-1 The name and function for the operation and display

● Setting for beeper sound in the event of power failure, etc.

("Setting" switch 1)... Factory setting: OFF

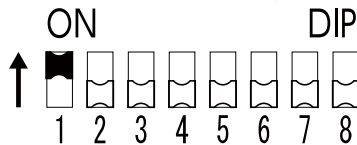

OFF: The beeper sounds when an alarm is necessary.

ON: The beeper does not sound for backup operation or battery replacement. The beeper sounds for other errors (connection capacity exceeded, operation error, etc.).

● Auto startup setting after recovery from power failure

("Setting" switch 2)... Factory setting: OFF

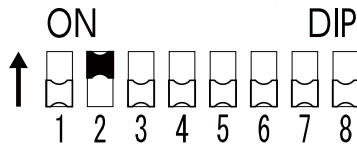

OFF: Automatically starts when power is restored.

After a power failure occurs and the unit shuts down using the shutdown software or contact signal(BS signal), the unit automatically starts and begins to output when the commercial power is restored.

ON: Does not automatically start when power is restored.

After the unit is shut down with the UPS monitoring software or contact signal (BS signal), it does not start up when commercial power is restored. Startup is performed by turning the "Power" switch OFF once, and then back ON again.

● Setting for whether or not to perform test once every 4 weeks

("Setting" switch 3)... Factory setting: OFF

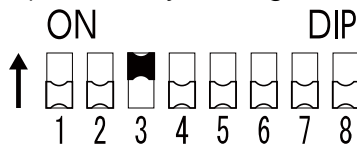

OFF: The self-diagnostic test is automatically executed once every 4 weeks.

ON: Does not perform the auto test once every 4 weeks.

Use this setting to disable Battery Mode for the regularly performed test.

● Auto startup mode setting

(“Setting” switch 4)... Factory setting: OFF

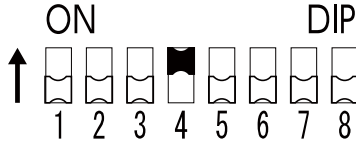

OFF: (Mode A) After UPS stopped, the UPS is automatically started immediately when “ON” is detected for the AC input.

ON: (Mode B) After UPS stopped, the UPS is automatically started in the AC input’s “OFF to ON” timing that is detected. (Definition of AC input OFF: When AC input is OFF for 1 second or more)

- * “Setting” switch 4 is valid when the auto startup after recovery from power failure setting (“Setting” switch 2) is set to OFF (auto restart is performed).
- * This setting mode is valid only after the UPS has been stopped by the contact signal backup stop signal (BS).
- * When a cable is connected to the RS232C port and the UPS monitoring software is used, the unit operates in Mode A regardless of this setting.

1) When BS signal is used to stop the UPS after a power failure occurs.

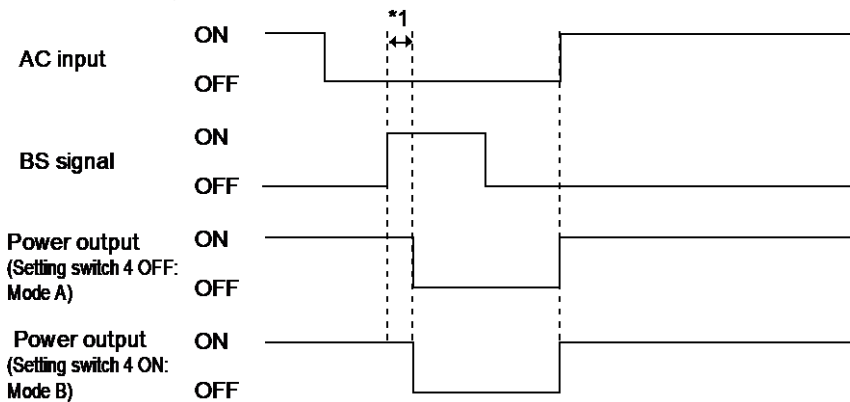

3 Check and start operation

3-1 The name and function for the operation and display

2) When BS signal is used to shut down the UPS when AC input is ON

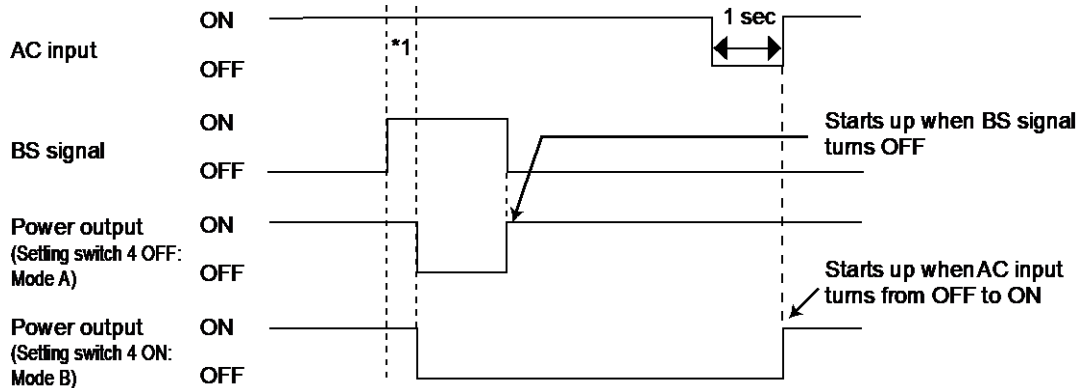

*1 For 10 seconds as a default setting.

● Logic of Remote on/off signal

("Setting" switch 5)... Factory setting: OFF

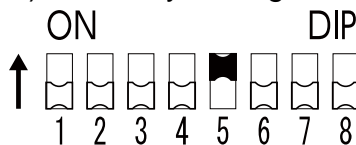

OFF: UPS start shutdown process when detecting close condition of remote input signal.

ON: UPS start shutdown process when detecting open condition of remote input signal.

● Synchronous/asynchronous operation setting

("Setting" switch 7, 8)... Factory setting: Refer to the table below.

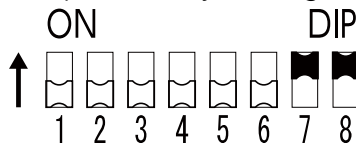

"Setting" switch 7	"Setting" switch 8	Operating mode
OFF	OFF	Commercial synchronous operation (ECO mode disabled)
OFF	ON	Commercial synchronous operation (ECO mode enabled)
ON	OFF	Asynchronous operation (50 Hz output)
ON	ON	Asynchronous operation (60 Hz output)

3-1 The name and function for the operation and display

7 OFF, 8 OFF: Commercial synchronous operation (ECO mode disabled)

- Output voltage: Inverter output in Commercial Power Mode. It is not affected by input voltage.
- Output frequency: Output in synchronization with input frequency.
- Bypass output: Bypass output in the event of failure or overload.

7 OFF, 8 ON: Commercial synchronous operation (ECO mode enabled)

- Output voltage: Input voltage is output as it is in Commercial Power Mode. (Low power consumption due to bypass output). Input voltage is output as it is.
- Output frequency: The same as the input frequency due to normally bypass output in Commercial Power Mode.

Note: When ECO mode enabled, after 5 minutes if the grid is within the voltage/frequency range of ECO mode (see the table below), UPS will transfer to ECO mode and working in the bypass.

Table: ECO mode range

Input AC Voltage	+/-10% of the nominal output voltage
Input AC Frequency(50Hz mode)	45.5~54.5Hz+/-0.5%
Input AC Frequency(60Hz mode)	55.5~64.5Hz+/-0.5%

7 ON, 8 OFF: Asynchronous operation (50 Hz output)

- Output voltage: Inverter output in Commercial Power Mode. It is not affected by input voltage.
- Output frequency: Always output with 50 Hz. It is not affected by input frequency.
- Bypass output: An output stops without bypass output in the event of failure or overload.

7 ON, 8 ON: Asynchronous operation (60 Hz output)

- Output voltage: Inverter output in Commercial Power Mode. It is not affected by input voltage.
- Output frequency: Always output with 60 Hz. It is not affected by input frequency.
- Bypass output: An output stops without bypass output in the event of failure or overload.

3 Check and start operation

3-1 The name and function for the operation and display

3-1-5 Beep sound

■ Type of beep sound

● Intermittent

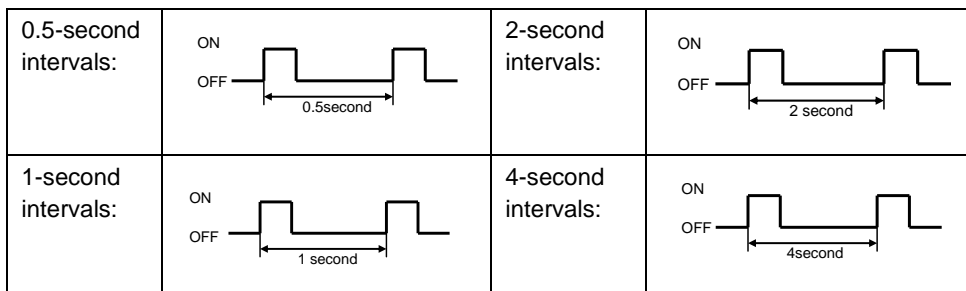

● Continuous

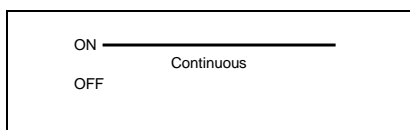

■ Stopping the beep sound

When the beep is sounding, you can stop it by pressing and holding the “STOP/TEST” switch for 0.5 seconds or longer.

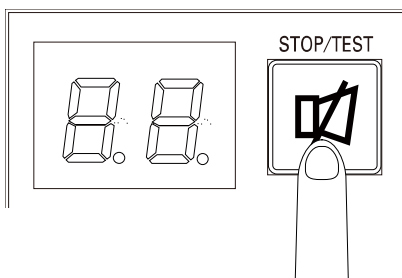

3-2 Checking the operation

When you finish connecting the unit, check that the Battery Mode is performed normally according to the following procedure.

1. Press the unit's "Power" switch to turn ON the power.
When the power turns on, the beeper sounds and self diagnosis starts automatically.
2. When the self-diagnosis test finishes normally, the unit's operation switches to commercial power and the status indication below is displayed.

Status indicator	Description
	"Power" switch "ON" Operating normally

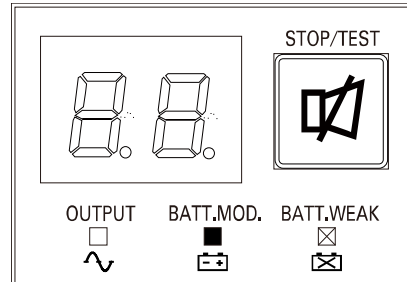

Additional Information

When the battery capacity is lower than the setting, the following display appears on 7 segment LED.

Status indicator	Description
	Battery charge is low, so the unit is waiting to start up.

() indicates blinking

3. Bring all the connected devices into operation. (Including devices connected to the AC outlet of your PC.)

However, operate the connected devices in a way that allows the power supply to be stopped at any time.

Note

- The UPS has been charged prior to shipment. However, if it is left for a long period of time, it may have self-discharged.
We recommend charging the UPS before using it. When you connect it to a commercial power source, battery charging automatically starts regardless of the ON/OFF state of the "Power" Switch and charging completes within 8 hours.

3 Check and start operation

3-2 Checking the operation

- 4.** Under this condition, check the unit's LED display and beep sound.

Are they in the same status as shown below?

Status indicator	
Beep	None
Power supply output receptacles	Outputs power (connected devices are powered)

If the same as the one shown above:

The operation is normal. Proceed to procedure 5.

If not the same as the one shown above:

The operation is abnormal. "3-4-4 Displays and beeps when there is an equipment failure" of "3-4 Interpreting beeps and displays" must apply.

Take necessary measures and then proceed to 5.

- 5.** Disconnect the unit's AC input from the commercial power. The unit enters Battery Mode.

- 6.** In Battery Mode, check the unit's LED display and beep sound.

Does the status indicator appear as one of those shown below? (: indicates blinking)

Status Indicator	Beep	Output	Description
	Intermittent 4-second intervals	ON	Backup is operating due to power failure or AC input error. Output will stop if Battery Mode continues.
	Intermittent 1-second intervals	ON	Backup is operating due to power failure or AC input error. Battery level is low, so output will stop soon.
	None	OFF	Battery is dead, so output stopped.

If not the same as one of those shown above:

... Operation is abnormal. Check the status of lamps and beep, and then press the "Power" switch to turn OFF the power.

- If the display is one of those shown in "3-4 Interpreting beeps and displays", take the necessary measures and then go back to procedure 1.
- If no Battery Mode is performed and the UPS and the devices connected to the UPS stop, this may be attributed to an insufficient battery charge. After connecting the AC input to the commercial power and charging the battery for at least 8 hours, go back to step 5.
- If the problem persists after checking the 2 points above, contact us.

 Additional Information

“Setting” switch 1 can be used to turn the beeper ON/OFF.

7. Reconnect the AC input to the commercial power source.

Status indicator returns to its normal state and the beeping sound stops.

(The status is as shown below.)

Status indicator	Description
	“Power” switch “ON” Operating normally

Checking the operation is now complete.

3-3 Start and stop procedures and basic operation

3-3-1 Start and stop procedures

For cautions when operating the UPS, including start and stop, refer to “Caution (for use)” shown in the “Safety precautions” of the beginning of this manual.

■ Start procedure

Turn on the “Power” switch of the UPS.

- Output begins in Inverter Operation a few seconds after the switch is activated. (Status indicator “On”)
- The status indicator displays “FU”, and the self-diagnostic test is performed in Battery Mode for about 10 seconds. (If the battery voltage is low, the self-diagnostic test is not performed. It is automatically executed after the battery is charged.) When the self-diagnostic test finishes successfully, switching to AC output from commercial power is performed and normal operation starts.
- When the self-diagnosis test finishes normally, the unit enters the normal operating state through inverter operation.
- When the self-diagnostic test is not performed, AC output begins immediately inverter operation.

Status indicator	On
Beep	None
Power supply output receptacles	Outputs power (connected devices are powered)

- During operation, the battery is charged automatically.

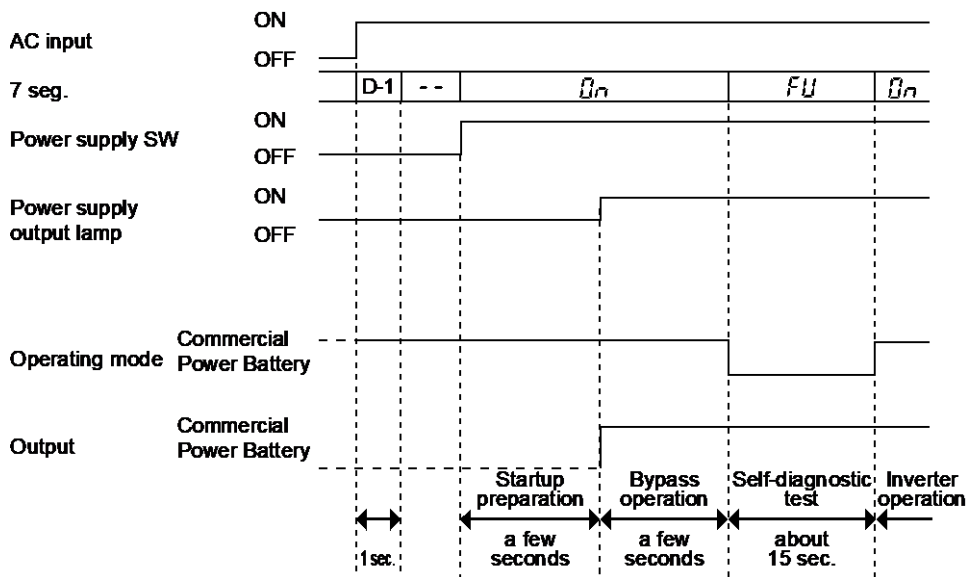

<Note>

D-1: Display the latest UPS fault mode (E₀, or E5, EE, --)
 (If there is no record for UPS fault, UPS display the "--".)

■ Operation when using

You may either leave the “Power” switch of the unit ON (operation status) or turn it OFF each time when stopping the connected system. Choose whichever operation method is more convenient.

We recommend turning OFF the “Power” switch when you do not use connected devices for a long time.

The battery can be charged once the AC input terminal is connected to a commercial power source.

■ Operation after a power failure

- If a power failure or abnormal input power supply occurs, the UPS automatically switches to Battery Mode, continuing power output from the Power Supply Output Receptacles and output terminal block supplied from the battery.
- The status is displayed and the beeper sounds intermittently to alert the user.

See also “Setting” switch 1 can be used to turn the beeper ON/OFF.

(: indicates blinking)

Icon	Beep	Output	Description
	Intermittent 4-second intervals	ON	Backup is operating due to power failure or AC input error. Output will stop if Battery Mode continues.
	Intermittent 1-second intervals	ON	Backup is operating due to power failure or AC input error. Battery level is low, so output will stop soon.
	None	OFF	Battery is dead, so output stopped.

■ Operation when a power failure is recovered

● When charge of the battery remains

The unit automatically resumes output via commercial power if it recovers from a power failure/input power supply error while Backup is operating. The spent battery starts charging.

● When charge of the battery does not remain

If a power failure or abnormal power input is resolved after the battery is discharged completely and power output is stopped, the UPS restarts automatically and resumes power output. The expended battery begins to charge.

3 Check and start operation

3-4 Interpreting beeps and displays

Additional Information

When the power is restored after a power failure, the UPS is set by default to automatically restart and supply power.

If you do not want to restart the connected devices, "Setting" switch 2 can be used to select whether or not auto restart is performed, or turn OFF the "Power" switch of the connected devices (See also "3-1-4 Setting Switch").

■ Operation when stopping

Note

Before stopping the commercial power to the unit, turn OFF the "Power" switch of the unit.

- The unit enters Battery Mode when commercial power is stopped. If you frequently use the unit in Battery Mode, the battery life may be significantly shortened.

Press and release the "Power" switch of the UPS, and then the "Power" switch turns OFF. The power output from the UPS stops at the same time.

Additional Information



Even if you turn off the "Power" switch, if AC is supplied from commercial power, the battery is automatically charged.

3-4 Interpreting beeps and displays

3-4-1 Displays and beeps in normal operations

- indicates the display is OFF
- indicates the display is ON
- ⋯ indicates blinking

(1) When "Power" switch is "OFF"

No.	Status indicator	Power supply output lamp	Battery mode lamp	Battery replacement lamp	Beep	Charging	Description	Solution
1		○	○	○	None	OFF	No AC input. Operation stopped.	---
2		○	○	○	None	ON	There is AC input. "Power" switch is OFF.	---
3		○	○	●	None	---	There is AC input. "Power" switch is OFF, or OFF⇒ON. Battery Disconnect or the self-diagnosis test detected a weak battery.	Connect Battery or replace the battery. You can replace the weak battery with a separately purchased replacement battery as needed. See also "4-2-2 Replacing the battery"

(2) When "Power" switch is "ON"

No.	Status indicator	Power supply output lamp	Battery mode lamp	Battery replacement lamp	Beep	Charging	Description	Solution
4	On	●	○	○	None	ON	"Power" switch is ON. Operating normally.	---
5	HS	○	○	○	None	ON	Battery charge is low, so the unit is waiting to start up.	Continue charging the battery. You can change the settings with Simple Shutdown Software.
6	Ec	●	○	○	None	ON	Operating normally in ECO mode.	For details on ECO mode, refer to "3-1-4 Setting Switch".

○ indicates the display is OFF
 ● indicates the display is ON
 ⋈ indicates blinking

3-4-2 Displays and beeps while testing

No.	Status indicator	Power supply output lamp	Battery mode lamp	Battery replacement lamp	Beep	Charging	Description	Solution
7	FU	●	●	○	None	OFF Discharging	Self-diagnostic test in progress.	---

NOT operation in bypass mode.

3-4-3 Displays and beeps during power failure or AC input error

○ indicates the display is OFF
 ● indicates the display is ON
 ⋈ indicates blinking

(1) When "Power" switch is "ON"

No.	Status indicator	Power supply output lamp	Battery mode lamp	Battery replacement lamp	Beep	Charging	Description	Solution
8	bU	●	●	○	Intermittent 4-second intervals	OFF Discharging	In Battery Mode due to power failure or AC input error. Output will stop if Battery Mode continues.	Perform shutdown operations for the connected devices and stop them.
9	bL	●	●	○	Intermittent 1-second intervals	OFF Discharging	(Same as above.) Battery level is low, so output will soon stop.	(Same as above.)
10	bE	○	●	○	None	OFF Discharging	Battery is dead, so output stopped. (This is displayed only for a few seconds.)	Charge the battery.

NOT operation in bypass mode.

(2) When "Power" switch is "OFF"

11	HH	○	○	○	None	(ON)	AC input voltage and AC input frequency are too high.	Use within the AC input voltage/frequency range described in the specifications.
12	-H	○	○	○	None	(ON)	AC input frequency is too high.	

3 Check and start operation

3-4 Interpreting beeps and displays

○ indicates the display is OFF
 ● indicates the display is ON
 : indicates blinking

No	Status indicator	Power supply output lamp	Battery mode lamp	Battery replacement lamp	Beep	Charging	Description	Solution
13	LH	○	○	○	None	(ON)	AC input voltage is too low and AC input frequency is too high.	Use within the AC input voltage/frequency range described in the specifications.
14	H-	○	○	○	None	(ON)	AC input voltage is too high.	
15	L-	○	○	○	None	(ON)	AC input voltage is too low.	
16	HL	○	○	○	None	(ON)	AC input voltage is too high and AC input frequency is too low.	
17	-L	○	○	○	None	(ON)	AC input frequency is too low.	
18	LL	○	○	○	None	(ON)	AC input voltage and AC input frequency are both too low.	

3-4-4 Displays and beeps when there is an equipment failure

○ indicates the display is OFF
 ● indicates the display is ON
 : indicates blinking

(1) When "Power" switch is "ON"

No	Status indicator	Power supply output lamp	Battery mode lamp	Battery replacement lamp	Beep	Charging	Description	Solution
19	OL	●	○	○	Intermittent 0.5-second intervals	ON Discharging	There are too many connected devices and the rated capacity is exceeded. If this state continues for as long as or longer than the times described below, commercial power continues to be supplied through bypass operation (Note 1) • When connection capacity is at 110% or higher: Bypass operation begins promptly.	Reduce the number of connected devices until the display appears as in status No. 4
20	OL blinking bP	● bypass	○	○	Intermittent 0.5-second intervals	ON Discharging		
21	CS	●	○	○	OFF	OFF	Battery charge stopped because the battery ambient temperature of 40°C or higher was detected.	Lower the ambient temperature to less than 40°C.
22	EO	○	○	○	Continuous	--- (Note 2)	Output stopped due to exceeded connection capacity.	Turn OFF the power switches of all devices connected to the unit reduce the number of connected devices, and turn the "Power" switch back ON again.

3 Check and start operation

3-4 Interpreting beeps and displays

- indicates the display is OFF
- indicates the display is ON
- ⋯ indicates blinking

No.	Status indicator	Power supply output lamp	Battery mode lamp	Battery replacement lamp	Beep	Charging	Description	Solution
23		○	○	○	Continuous	--- (Note 2)	Check that the connection capacity has not exceeded the rated capacity.	Check that the AC input of connected devices is not short-circuited, or that the connection capacity does not exceed the rated capacity.
24		○	○	○	Continuous	OFF	Failure occurred. When the "Buzzer Pause/Test" switch is pressed, the details of the error are displayed (No. 26 to 31).	Turn OFF this unit and all connected devices. Then, turn the "Power" switch back ON for this unit only. If the display does not change, there is a problem with this unit. Contact the shop of purchase or our Electronic Systems & Equipments Customer Support Center.
25	 blinking 	--- (Note 2)	○	○	Continuous	--- (Note 2)		
26		● bypass	○	○	Continuous	--- (Note 2)	Switched to bypass operation due to abnormal rise in output voltage. (Note 1).	Displays the details of the error that occurred only while pressing the "Buzzer Pause/Test" switch while in state No. 25.
27		● bypass	○	○	Continuous	--- (Note 2)	Switched to bypass operation due to abnormal drop in output voltage. (Note 1).	(Same as above.)
28		● bypass	○	○	Continuous	OFF	Stopped charging due to abnormal rise in battery charge voltage. When the battery discharges, bypass output is performed. (The display disappears completely.)	Displays the details of the error that occurred only while pressing the "Buzzer Pause/Test" switch while in state No. 24.
29		● bypass	○	○	Continuous	OFF	Stopped charging due to abnormal drop in battery charge voltage. When the battery discharges, bypass output is performed. (The display disappears completely.)	(Same as above.)
30		● bypass	○	○	Continuous	--- (Note 2)	Moved to bypass operation due to problem with the internal temperature (Note 1).	Displays the details of the error that occurred only while pressing the "Buzzer Pause/Test" switch while in state No. 25.
31		● bypass	○	○	Continuous	--- (Note 2)	Moved to bypass operation due to problem with the DC Bus voltage. (Note 1).	(Same as above.)

3 Check and start operation

3-4 Interpreting beeps and displays

○ indicates the display is OFF
 ● indicates the display is ON
 ⋯ indicates blinking

No.	Status indicator	Power supply output lamp	Battery mode lamp	Battery replacement lamp	Beep	Charging	Description	Solution
32	<i>E_c</i>	● bypass	○	○	Continuous	--- (Note 2)	Moved to bypass operation due to problem with the half wave rectification load (Note 1) (Note 3)	(Same as above.)
33	<i>E_F</i>	○	○	○	Continuous	--- (Note 2)	External Fan Error.	(Same as above.)

Note 1: In bypass operation, commercial power is output directly. Output stops when a power failure (AC input OFF) occurs in bypass operation.

Note 2: The displays and operations vary according to the status.

Note 3: Devices such as dryers, some solenoid valves, etc., which have a half-wave rectifier.

(2) When "Power" switch is "OFF"

34	<i>EE</i>	○	○	○	Continuous	OFF	Failure occurred. When the "Buzzer Pause/Test" switch is pressed, the details of the error are displayed.	There is a problem with the unit. Contact the shop of purchase or the OMRON Electronic Systems & Equipments Customer Support Center.
35	<i>E3</i>	○	○	○	Continuous	OFF	Stopped charging due to abnormal rise in battery charge voltage.	Turn off AC input.
36	<i>E4</i>	○	○	○	Continuous	OFF	Stopped charging due to abnormal drop in battery charge voltage.	(Same as above.)

3-4-5 Display and beep for battery replacement

○ indicates the display is OFF
 ● indicates the display is ON
 ⋯ indicates blinking

No.	Status indicator	Power supply output lamp	Battery mode lamp	Battery replacement lamp	Beep	Charging	Description	Solution
37	<i>On</i>	●	○	●	Intermittent 2.0-second intervals	ON	The self-diagnosis test detected a weak battery, or Battery life counter went off-scale. (Warning only. Outputs continue.)	Replace the battery. You can replace the weak battery with a separately purchased replacement battery as needed. See also "4-2 Replacing the battery".
38	<i>bu</i>	---	---	---	Continuous	OFF	Battery life counter has been reset.	Wait for a few seconds. Move to status No.4.

3-5 UPS operation mode settings

3-5-1 Settable items and explanations

There are seven items to select.

- 1) Output voltage setting
- 2) Maximum backup time setting
- 3) Reboot battery voltage setting
- 4) BS signal delay setting
- 5) BU signal delay setting
- 6) Dry contact logic setting
- 7) Dry contact test

The settings available for this operation are shown below.

1. Output voltage setting (100V/110V/115V/120V)

Four types of output voltage can be set. (Setting range: 100V/110V/115V/120V, Default setting: 100V)

Output is performed at the set voltage, with no relation to the input voltage.

2. Maximum backup time setting

Maximum backup time can be set. (Setting range: 0 to 90 minutes, Default setting: 0 minute)

3. Reboot battery voltage setting

The limit battery capacity for wake-up can be set. (Setting range: 0 to 90%, Default setting: 0%)

4. BS signal delay setting

It is possible to set the delay time for stopping the power supply output after the BS signal is received. (Setting range: 0 to 10 minutes, Default setting: 0 minute)

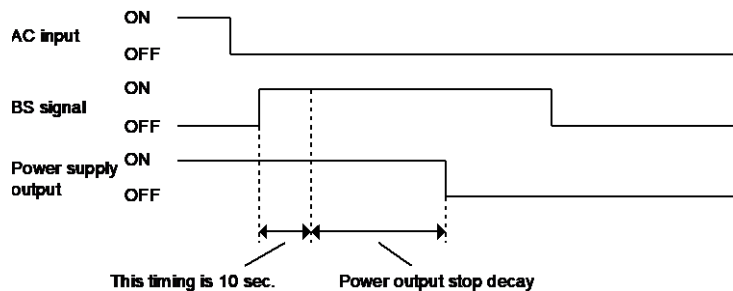

5. BU signal delay setting

It is possible to set the delay time of BU signal after AC fail occur. (Setting range: 0 to 90 seconds, Default setting: 0 second)

3 Check and start operation

3-5 UPS operation mode settings

6. Dry contact logic setting (BU,BL,TR,WB)

Four types of output signal can be set On/Off (See also "6-1 Contact signal functions").

7. Dry contact test (BL/TR/BU/WB/BS/remote)

- Four types of output signal can be forcibly turned ON.
- The ON/OFF state of two types of input signal can be checked with the status indicator and the beeper.

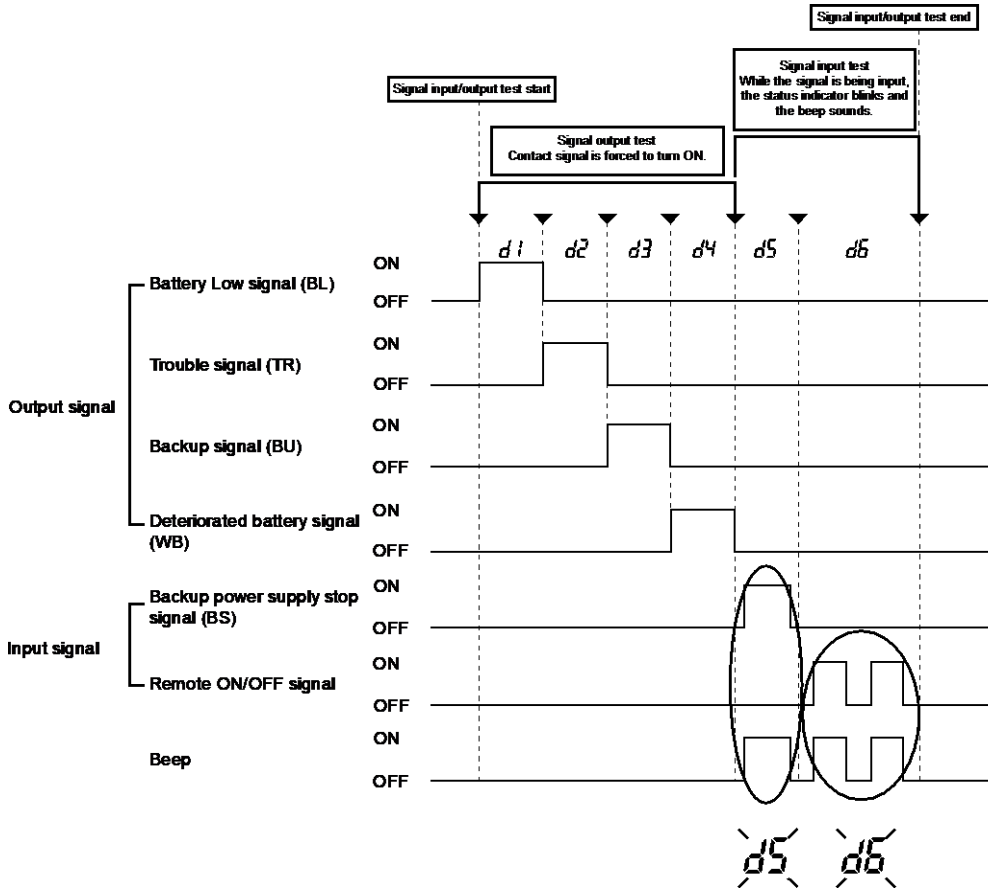

While the signal is being input, these status indications blink and the beep sounds.

3-5-2 Settings

The UPS operation mode can be set if the “Power” switch is turned ON while the “Buzzer Pause/Test” switch is pressed.

Note: While in setting mode, output from the power supply output is OFF even if the “Power” switch is ON.

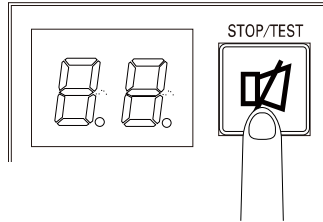

(1) When the “Buzzer Pause/Test” switch is briefly pressed (for less than 1 second), the next item is displayed.

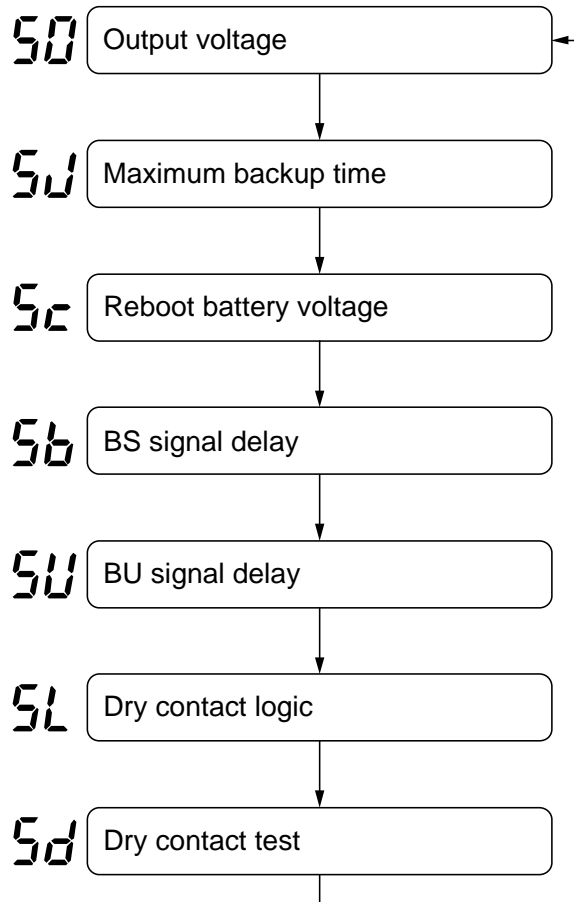

(2) The unit enters the “individual item setting mode” when the “Buzzer Pause/Test” switch is pressed and held (for more than 1 second).

3 Check and start operation

3-5 UPS operation mode settings

(3) When the "Power" switch is turned OFF, the setting mode quits and the unit enters "Power" switch OFF status (status = - -).

Operation (A) : pressing the "Buzzer Pause switch" and turn on the "Power" switch.

Operation (B) : pressing the "Buzzer Pause switch" under 1 second and then release it.

Operation (C) : pressing the "Buzzer Pause switch" 1 to under 5 second and then release it.

Operation (D) : pressing the "Buzzer Pause switch" 5 second or more and then release it.

Operation (E) : turning off the "Power" switch.

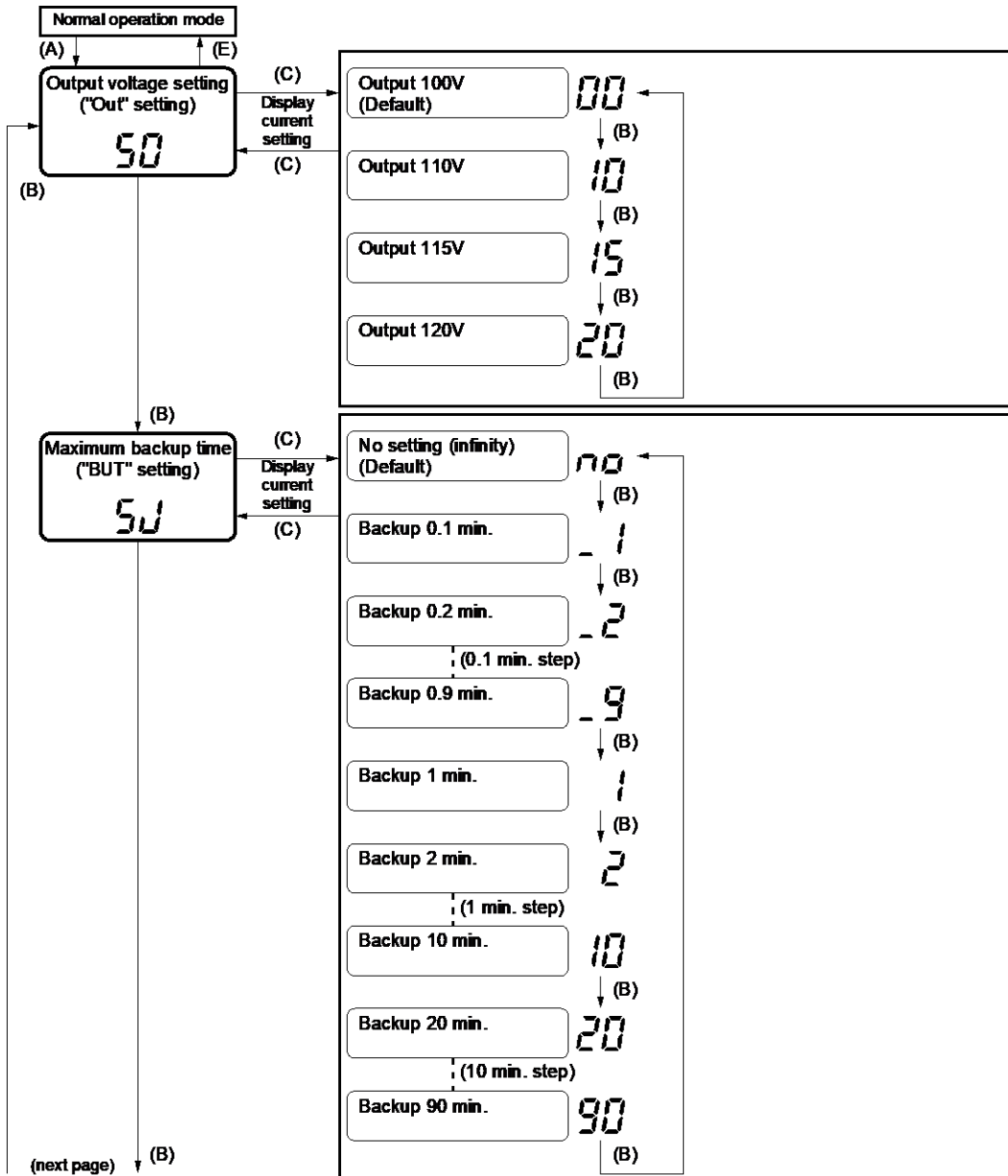

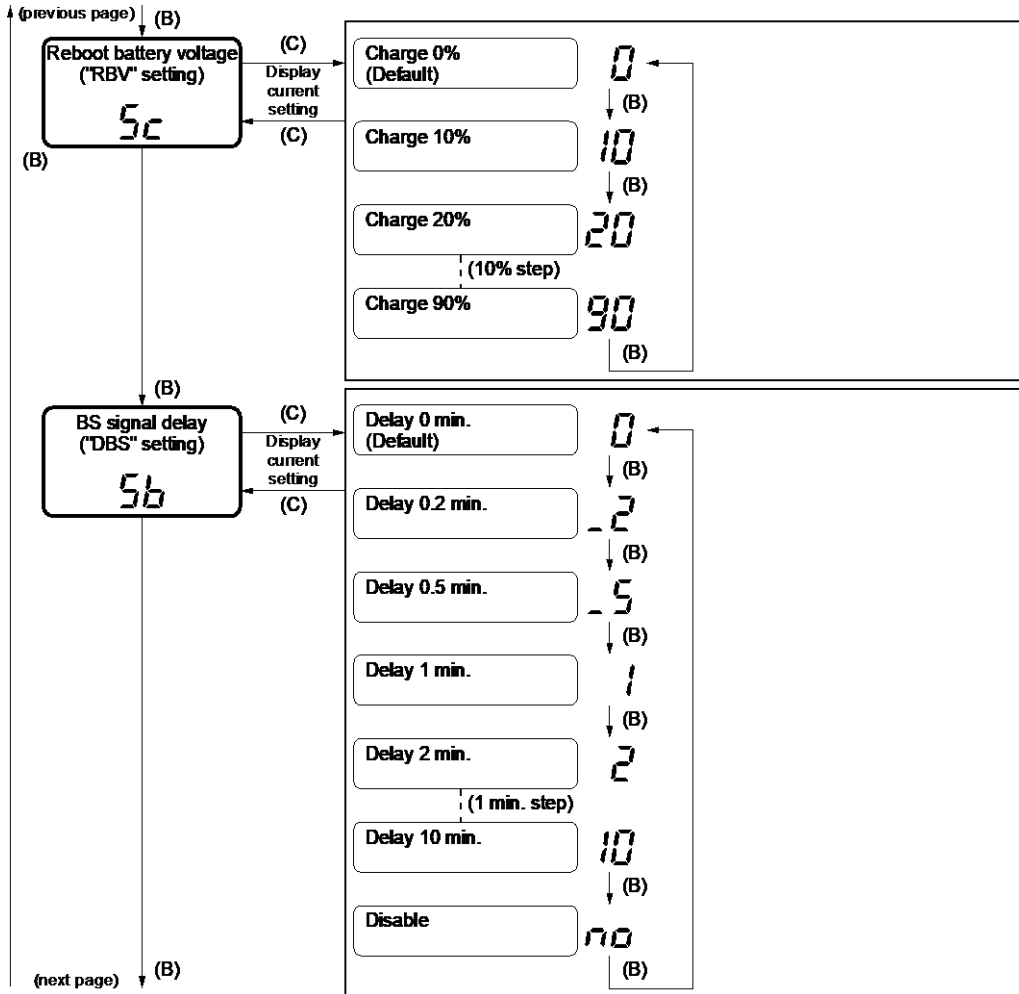

3 Check and start operation

3-5 UPS operation mode settings

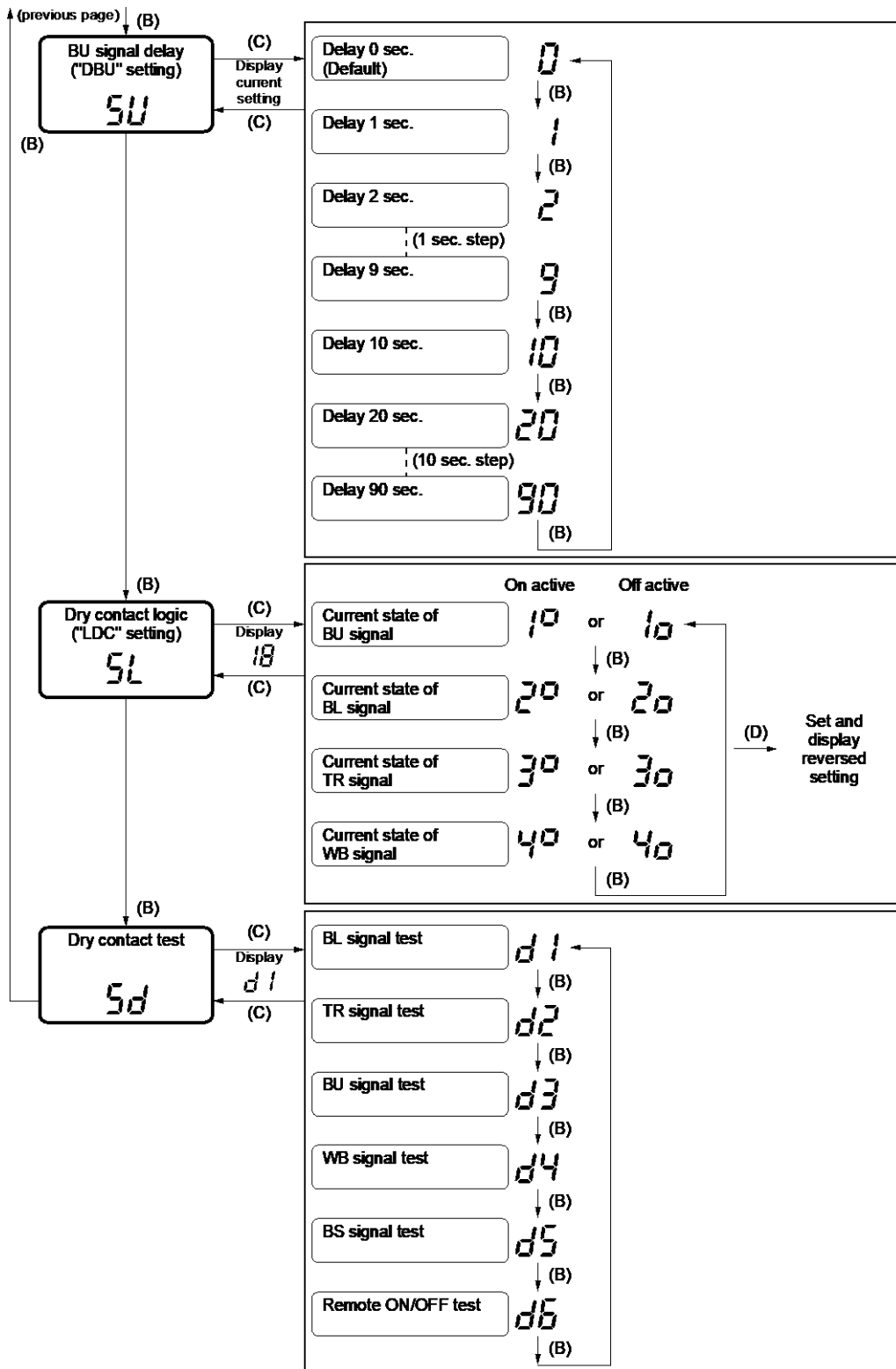

4 Maintenance and Inspection

For cautions when maintaining the UPS, refer to “Caution (for maintenance)” shown in the “Safety precautions” of the beginning of this manual.

4-1 Checking the battery

The lead battery used in the unit has a limited lifespan.

(The life varies depending on your storage/use environment and backup frequency.)

The nearer the end of the life is, the more rapidly deterioration proceeds.

4-1-1 Battery life expectancy

(* Not a guaranteed performance)

Ambient temperature	Battery life expectancy
25°C	5 years
30°C	3.5 years
35°C	2.5 years
40°C	1.7 years

4-1-2 Self-diagnosis test

This test performs a failure diagnosis on the unit and performs a test to check for battery deterioration.

Use the procedure below to check whether a circuit failure has occurred inside the unit and whether battery replacement is required.

There are two, automatic testing and manual testing, in the self-diagnosis test as follows.

■ Automatic testing

The self-diagnosis test is automatically performed at the factory settings, at the following timing in the state that the UPS is connected to a commercial power source and the charge of the battery has been completed. User's operation to start the test is unnecessary.

- When the “Power” switch is turned ON from OFF
- Performed with one time per four weeks on the condition that the “Power” switch is ON

When charge of the battery is not completed, the self-diagnosis test is not performed immediately.

It is performed automatically after the completion of charge.

4 Checking the battery

4-1 Checking the battery

Manual testing

This test can also be performed manually. Press and hold the “Buzzer Pause/Test” switch of the UPS for 5 seconds or longer. When the beeper begins to sound intermittently, release the Switch.

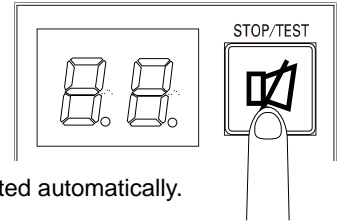

By performing the self-diagnosis test, backup operation is started automatically.

(Status indicator “ \overline{FL} ”, No beep sounds.)

After the test is completed, UPS automatically returns to the normal operation.

If the status indicator/battery replacement lamp blinks and the beeper sounds: See also “3-4 Interpreting beeps and displays”.

Additional Information

- Follow the directions for the solutions described in “3-4-4 Displays and beeps when there is an equipment failure” and “4-2 Replacing the battery”.
- The self-diagnosis test can be performed also from attached UPS monitoring software. For more details, refer to the online help of UPS monitoring software.

4-1-3 Estimated backup time

The backup time varies depending on the capacity of connected devices.

After calculating the total capacity of connected devices, refer to the graph of the backup time to obtain an estimation of the initial value of the backup time. (This is also applied to checking the battery.)

1. Convert the total capacity (power consumption) of the connected devices to watts (W).
For the indication of connected devices, check your computer and the rear of the display. The indicator can show values in three different ways: volt-amperes (VA), amperes (A), and watts (W).

Example 1) 100 VAC, 50/60 Hz, 145 W
Example 2) 100 VAC, 50/60 Hz, 1.8 A
Example 3) 100 VAC, 50/60 Hz, 150 VA

Indication	Value
A	$A \times \text{power factor} \times 100 = W$
VA	$VA \times \text{power factor} \times 100 = W$

For devices that use the VA or A indication, convert the capacity into W. Multiply the value indicated on devices by the value in the right table for conversion.

(When the power factor is unknown, enter “1”. The power factor usually ranges between 0.6 and 1.)

2. Add the values converted into W to obtain the total capacity of the connected devices.
3. Calculate the initial value of the backup time for the total capacity of the connected devices from the graph below.
 - Graph of backup time (graph of initial values for products that have not been used at 25°C). The backup time becomes shorter than the graph (table) below when temperature is lower.
 - The smaller the capacity of connected devices becomes, the longer the backup time becomes.

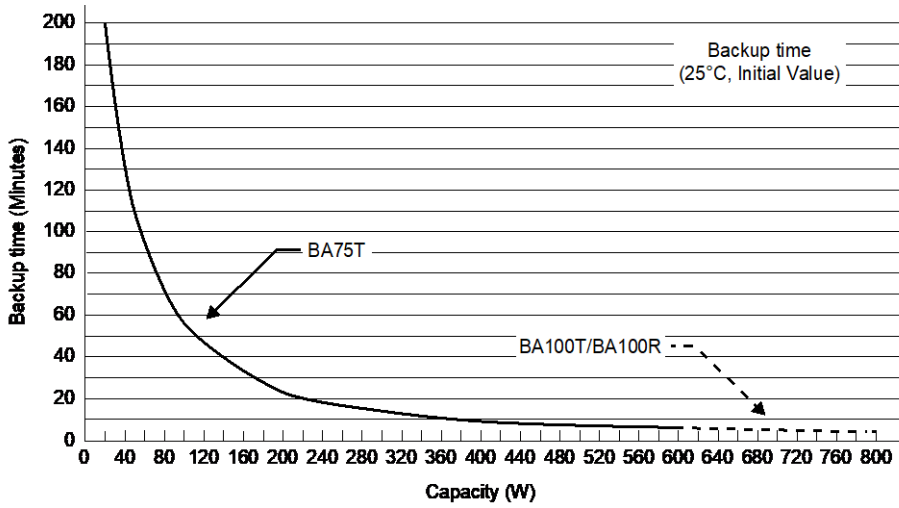

Backup time table Time unit: (Minutes)

BA75T

Connection capacity (W)	20	50	100	200	300	400
Backup time (Minutes)	200	109	56	23	14	9

BA100T/BA100R

Connection capacity (W)	20	50	100	200	300	400	600	800
Backup time (Minutes)	200	109	56	23	14	9	6	4

Note: These backup times are for reference only. Times may vary according to battery life and external environmental conditions (temperature, etc.).

4-2 Replacing the battery

The battery can be replaced while the unit is stopped (power supply output stopped).

Refer to the below-shown reference data “life of the battery” for the details about the life of the battery.

Caution (for battery replacement)

Risk of explosion if battery is replaced by an incorrect type. When replacing batteries replace with the same type and number of batteries or battery packs.



Notes

Be sure to reset the battery life counter after replacing the battery. Press and hold the “Buzzer Pause/Test” switch of the UPS for 10 seconds or longer to reset the battery life counter. Resetting is complete when “bJ” is displayed.

- Perform a reset with the “AC input” ON.
- Stopping (“Power” switch OFF): When the beeper becomes a sustained beep, release the switch.
- In Commercial Power Mode (“Power” switch ON): When the beeper changes from intermittent beeps to a sustained beep, release the switch.

If you do not reset the battery life counter, a battery deterioration alarm may occur faster than the expected battery life.

If you replace the battery while operating, please conduct a self-diagnostic test.

- Press “buzzer stop / test” switch for 5 seconds to 9 seconds and release the switch when the buzzer beeps (intermittent sound).
- After the self-diagnostic test is started and the test is completed, it automatically returns to the operation mode.
- When the unit is used in compliance with UL standards, battery replacement should be performed or supervised by personnel familiar with the danger of batteries and the required precautions.
- If an input power supply error such as a power failure occurs when replacing the battery while in operation, backup cannot be performed and output stops.
- Do not replace the battery while the UPS is operating in backup mode. Output will stop.



Additional Information

When the battery replacement LED lights blinks and beeper sounds, press the “Buzzer Pause/Test” switch for 0.5 seconds to stop the beeper. (Blinking of “battery replacement” LED does not disappear.)

4-2-1 Notification that the battery needs to be replaced

This Battery life counter function notifies you with LED display blinking when the battery needs to be replaced.

The battery life is determined by the counter function and the self-diagnosis test. The battery life counter operates while commercial power is supplied after shipment. (When the ambient temperature of the battery is higher than 25°C, the value of the counter will be incremented at a faster pace.)

Notes

The lead battery used in the unit has a limited lifespan. The life varies depending on your storage/use environment and backup frequency.

- The nearer the end of the life is, the more rapidly deterioration proceeds.

Refer to the below-shown reference data "Battery life" for the details about the life of the battery.

The battery deteriorates even if it is stored. The higher the temperature is, the shorter the life becomes.

■ Guidelines for how often to check the battery

Average ambient temperature	6-month check	Monthly check
40°C	For the first 1 years after starting use	When 1 years or more have passed after starting use
30°C	For the first 3 years after starting use	When 3 years or more have passed after starting use
25°C	For the first 4 years after starting use	When 4 years or more have passed after starting use

4 Replacing the battery

4-2 Replacing the battery

4-2-2 Procedure for replacing the battery

For cautions when replacing the battery of the UPS, refer to "Caution for battery replacement)" shown in the "Safety precautions" of the beginning of this manual.

■ BA75T/BA100T

1. Use a hex screwdriver or wrench to loosen (turn counterclockwise) the 2 screws at the top of the front panel of the unit, until they turn freely. (1)
Lift the front panel up and pull toward you to remove. (2)

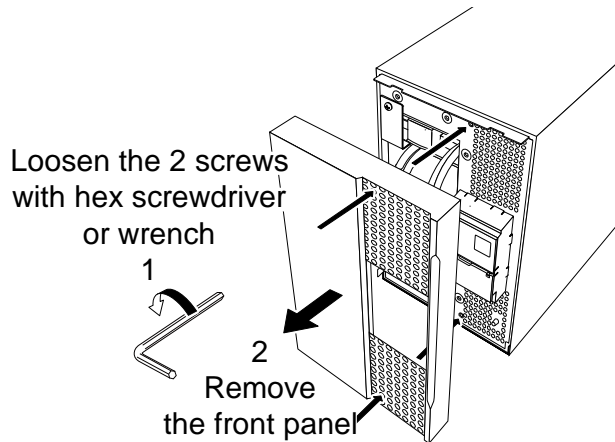

2. Remove the battery cable from the cable holder. (1)
Hold the battery connector, and pull the connectors apart. (2)

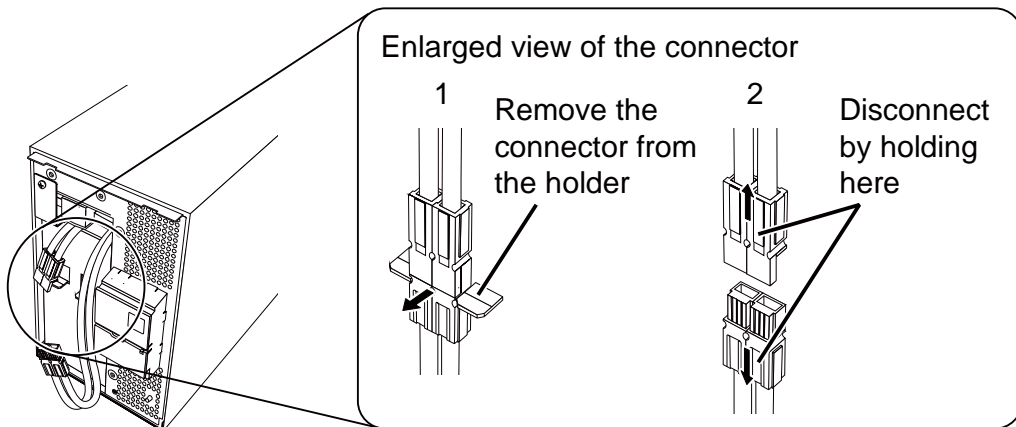

- 3.** Turn the screw that fix the plate cover counterclockwise to remove them. (1)
Pull the plate cover towards you (2) and lift it up to remove it. (3)

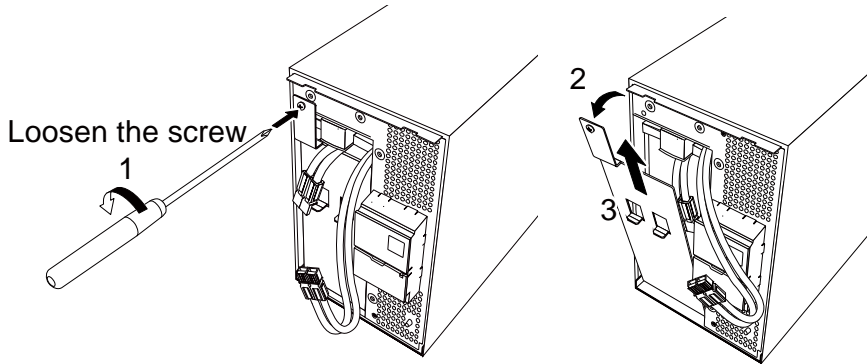

- 4.** Hold the pullout label at the bottom of the battery pack and remove the battery pack.

Caution (for maintenance)

Do not hold the connector or cable of the battery pack.



Use the red tape on the top of the battery pack, which is 10 cm from the inner edge of the battery, to gauge how much further you need to pull the battery to remove it. Hold the battery securely with both hands so as not to drop it.

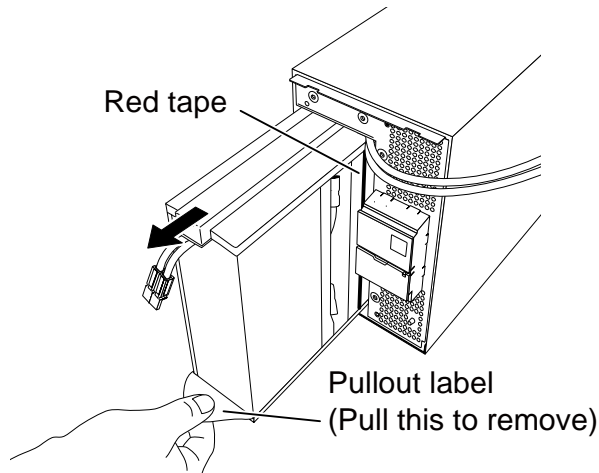

4 Replacing the battery

4-2 Replacing the battery

5. Insert a new battery into the UPS as far as it will go.

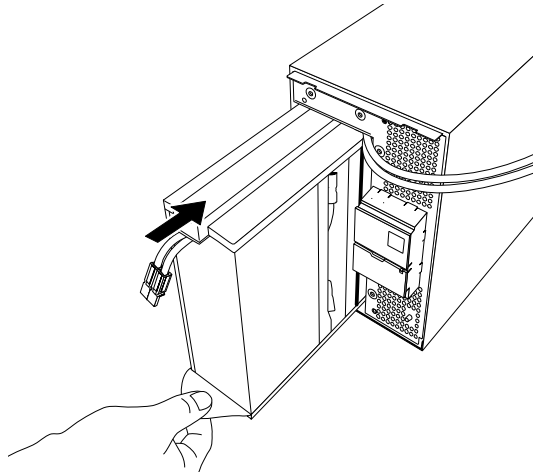

● Replacement battery pack

BA75T/BA100T: Model BAB100T

6. Attach the plate cover in order of (1 to (2).
Use a screwdriver to securely tighten (clockwise) the screw you removed. (3)
Do not pinch the cable with the plate cover.

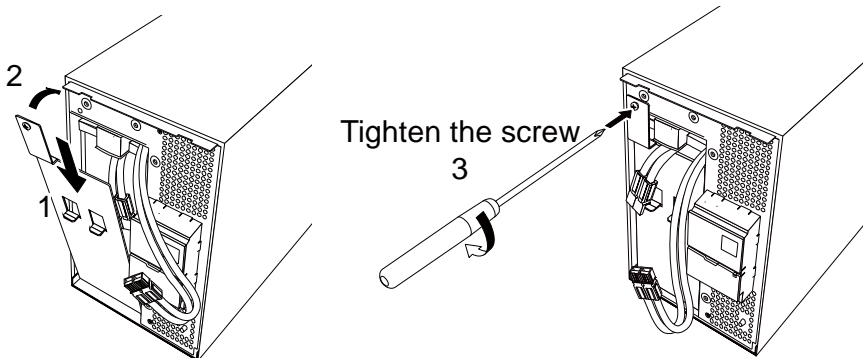

- 7.** Insert the battery connector until it is locked. (1)
Install the battery cable in the cable holder. (2)

Note: You may hear a “pop” sound when you connect the battery if it is replaced after the unit’s operation is stopped, but this sound is not abnormal.

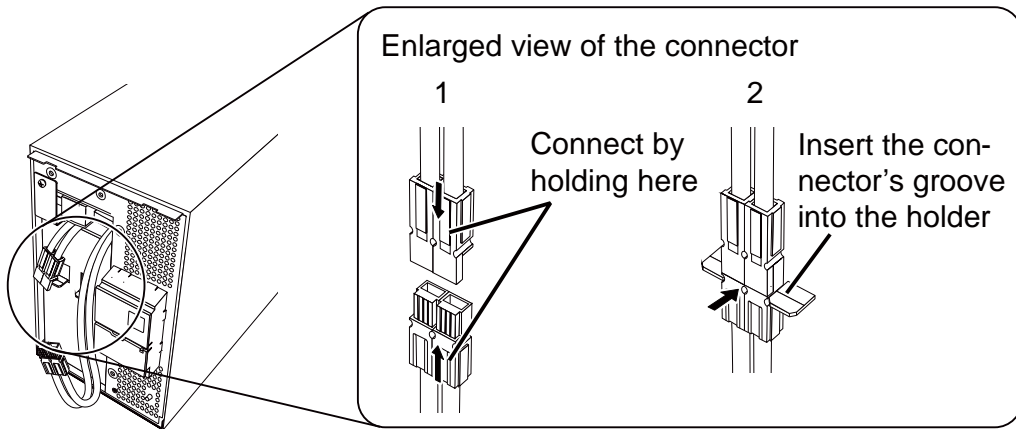

- 8.** Attach the front panel to the unit. (1)
Use a hex screwdriver or wrench to securely tighten (clockwise) the 2 screws at the top of the front panel. (2)

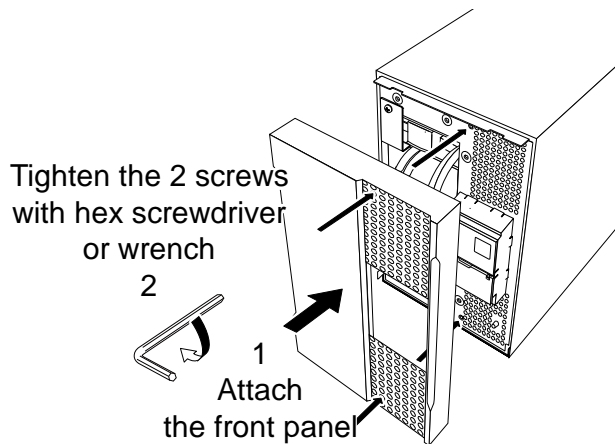

- 9.** Perform the self-diagnosis test.

In Status Indicator “”

The self-diagnosis test is automatically performed by operation shown in “2-3 Connecting the AC Input” and “3-3-1 Start and Stop procedure ■ Start procedure”.

※If Status Indicator does not show “”,

Check connector insertion as shown in “4-2-2 Procedure for replacing the battery 7. Insert the battery connector until it is locked”. When the connector is not fully inserted, insert the connector again.

4 Replacing the battery

4-2 Replacing the battery

In Status Indicator “**—**”

The self-diagnosis test is automatically performed by operation shown in “3-3-1 Start and Stop procedure ■ Start procedure”.

※If Status Indicator does not show “**0r**”,

Check connector insertion as shown in “4-2-2 Procedure for replacing the battery 7. Insert the battery connector until it is locked”. When the connector is not fully inserted, insert the connector again.

In Status Indicator “**0r**”

The self-diagnosis test is performed by operation shown in “4-1-2 self-diagnosis test ■ Manual testing”.

10. Reset the battery life counter.

Press and hold the “Buzzer Pause/Test” switch of the UPS for 10 seconds or longer. Resetting is complete when “**b4**” is displayed.

11. Check “Battery replacement” LED.

※If “Battery replacement” LED is OFF

Move to the next No.12.

※If “Battery replacement” LED is blinking

(1) Check connector insertion as shown in “4-2-2 Procedure for replacing the battery 7. Insert the battery connector until it is locked”. When the connector is not fully inserted, insert the connector again.

(2) Check the battery as shown in “4-2-2 Procedure for replacing the battery 4. Hold the pullout label at the bottom of the battery pack and remove the battery pack”. When the battery is not yet replaced, replace the battery.

(3) Reset the battery life counter as shown in “4-2-2 Procedure for replacing the battery 10. Reset the battery life counter”.

If “Battery replacement” LED is still blinking, contact us.

12. Stick the related Battery replacement date label on the Unit after writing the battery replacement date.

Battery replacement is now complete.

■ BA100R

1. Use a hex screwdriver or wrench to loosen (turn counterclockwise) the 2 screws at the top of the front panel of the unit. (1)

Pull the right side of the front panel towards you to remove it. (2)

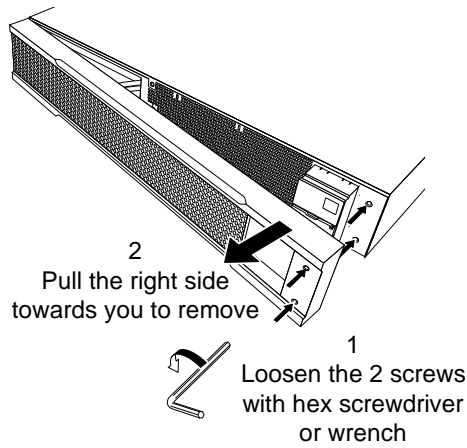

- 2.** Remove the battery cable from the cable holder. (1)
Hold the battery connector, and pull the connector apart. (2)

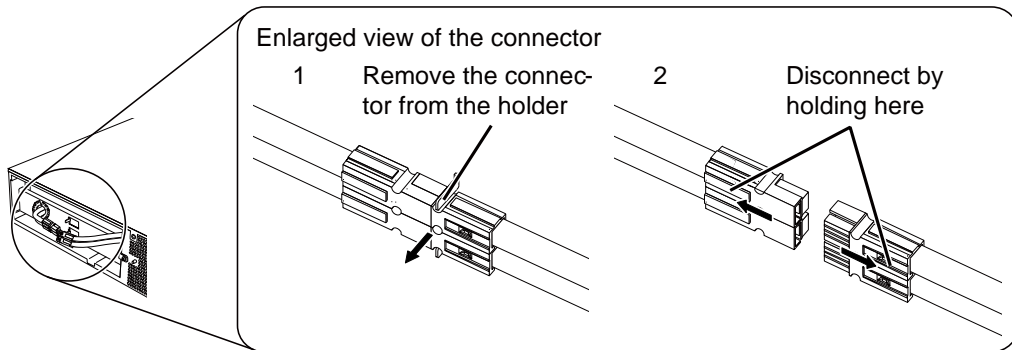

- 3.** Turn the screw that fix the plate cover counterclockwise to remove them. (1)
Pull the plate cover right (2 and pull the left side towards you to remove it. (3)

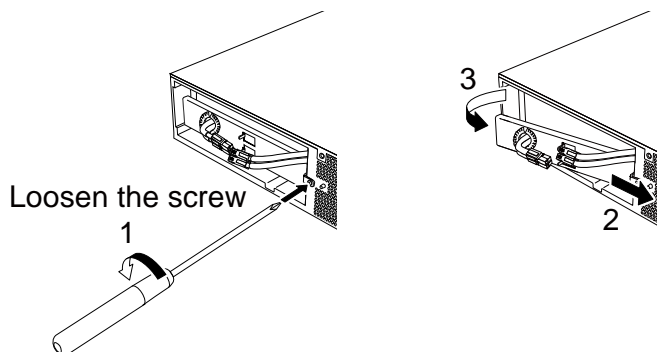

4 Replacing the battery

4-2 Replacing the battery

4. Hold the pullout label at the bottom of the battery pack and remove the battery pack.

Caution (for maintenance)

Do not hold the connector or cable of the battery pack.



Use the red tape on the top of the battery pack, which is 10 cm from the inner edge of the battery, to gauge how much further you need to pull the battery to remove it. Hold the battery securely with both hands so as not to drop it.

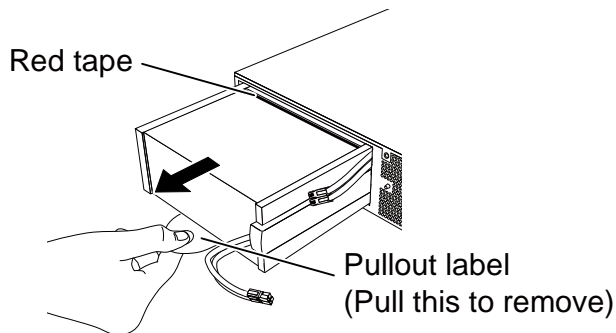

5. Insert a new battery into the UPS as far as it will go.

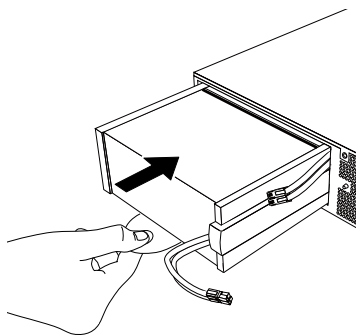

● Replacement battery pack

BA100R: Model BAB100R

- 6.** Attach the plate cover in order of (1 to (2).
Use a screwdriver to securely tighten (clockwise) the screw you removed. (3)
Do not pinch the cable with the plate cover.

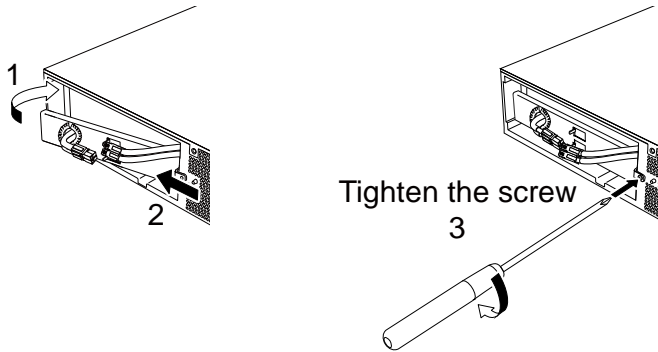

- 7.** Insert the battery connector until it is locked. (1)
Install the battery cable in the cable holder. (2)

Note: You may hear a “pop” sound when you connect the battery if it is replaced after the unit’s operation is stopped, but this sound is not abnormal.

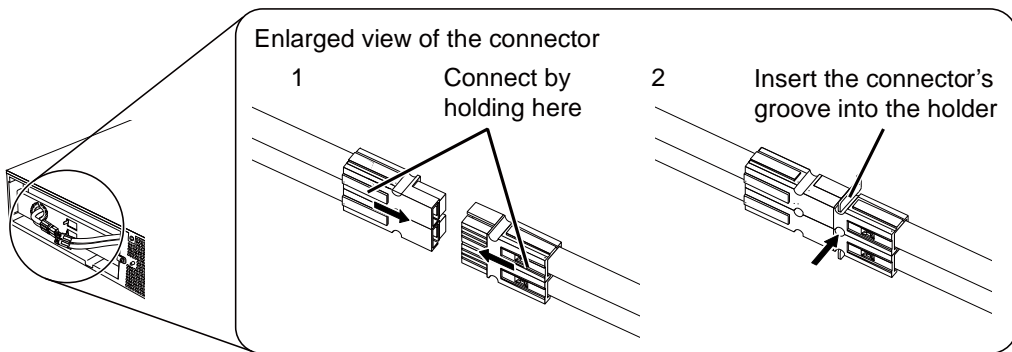

4 Replacing the battery

4-2 Replacing the battery

8. Attach the front panel to the unit.

Insert the tab on the left side of the front panel into the hole in the main unit, and push the front panel towards the main unit. (1)

Use a hex screwdriver or wrench to securely tighten (clockwise) the 2 screws at the top of the front panel. (2)

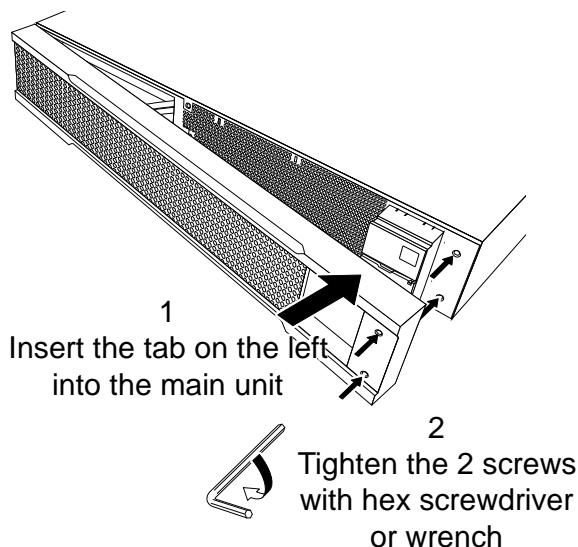

9. Perform the self-diagnosis test.

In Status Indicator “

The self-diagnosis test is automatically performed by operation shown in “2-3 Connecting the AC Input” and “3-3-1 Strat and Stop procedure ■ Start procedure”.

※If Status Indicator does not show “

Check connector insertion as shown in “4-2-2 Procedure for replacing the battery 7. Insert the battery connector until it is locked”. When the connector is not fully inserted, insert the connector again.

In Status Indicator “

The self-diagnosis test is automatically performed by operation shown in “3-3-1 Strat and Stop procedure ■ Start procedure”.

※If Status Indicator does not show “

Check connector insertion as shown in “4-2-2 Procedure for replacing the battery 7. Insert the battery connector until it is locked”. When the connector is not fully inserted, insert the connector again.

In Status Indicator “

The self-diagnosis test is performed by operation shown in “4-1-2 self-diagnosis test ■ Manual testing”.

10. Reset the battery life counter.

Press and hold the “Buzzer Pause/Test” switch of the UPS for 10 seconds or longer. Resetting is complete when “

70

11. Check “Battery replacement” LED.

※If “Battery replacement” LED is OFF

Move to the next No.12.

※If “Battery replacement” LED is blinking

- (1) Check connector insertion as shown in “4-2-2 Procedure for replacing the battery 7.Insert the battery connector until it is locked”. When the connector is not fully inserted, insert the connector again.
- (2) Check the battery as shown in “4-2-2 Procedure for replacing the battery 4.Hold the pullout label at the bottom of the battery pack and remove the battery pack”. When the battery is not yet replaced, replace the battery.
- (3) Reset the battery life counter as shown in “4-2-2 Procedure for replacing the battery 10. Reset the battery life counter”.

If “Battery replacement” LED is still blinking, contact us.

12.Stick the related Battery replacement date label on the Unit after writing the battery replacement date.

Battery replacement is now complete.

4-3 Replacing the fan

The fan in the unit has an expected lifespan of approximately 5 years.

Replace it when the Error Lamp is lit and the fan is stopped.

Stop the UPS and disconnect the AC input from the commercial power.

Caution (for replacing the fan)

When this product is used in compliance with UL standards, do not replace the fan.

- Fan replacement does not comply with UL standards.



Do not insert your hand or metal objects into the fan recess.

- Doing so may cause electric shock or short-circuit.



Do not put your fingers into the fan.

- The fan spins when connecting the AC input.
- Doing so may result in injury.



4-3-1 Fan replacement procedure

■ BA75T/BA100T

Make sure that UPS doesn't connect to any AC inputs and the fan stops.

1. Use a screwdriver to loosen (turn counterclockwise) and remove the 2 screws on the fan cover above the fan on the back of the unit. (1)
Remove the fan cover. (2)

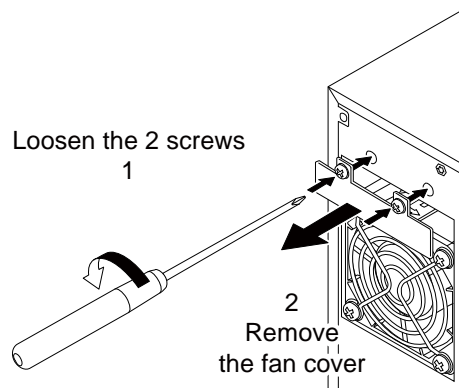

2. Use a screwdriver to loosen (turn counterclockwise) and remove the 4 cooling fan screws and the fan guard. (1)
Pull the fan toward you to remove it. (2)

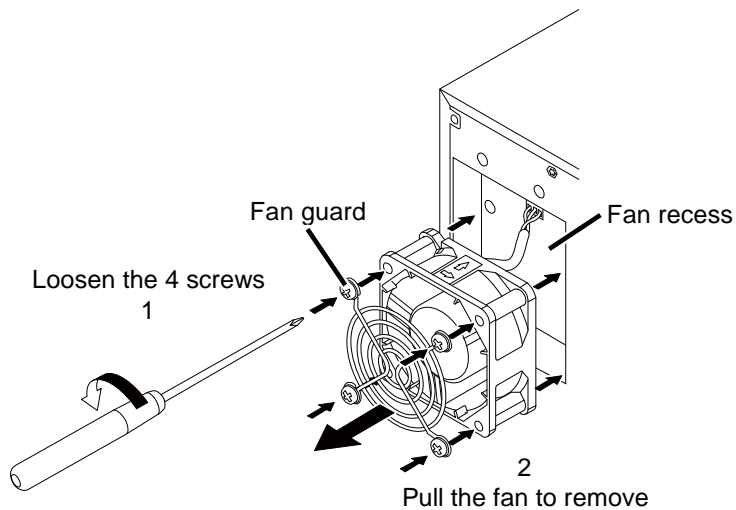

3. While pressing up on the tip of the fan connector (1, pull it toward you to disconnect it. (2)

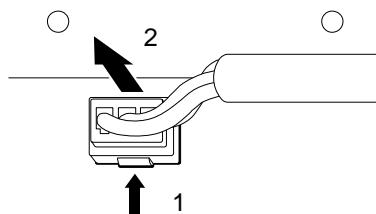

4 Replacing the fan

4-3 Replacing the fan

4. Insert the new fan connector until it clicks into place. (3)

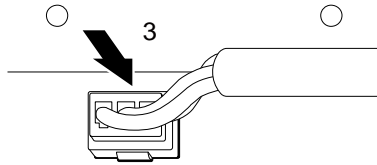

● Replacement fan

BA75T/BA100T/BA100R: Model BAF100R

5. Insert the fan and the fan guard into the unit's fan recess. (1)
Use a screwdriver to securely tighten (turn clockwise) the 4 removed screws. (2)
When doing so, make sure the cable does not become pinned under the fan's cover.

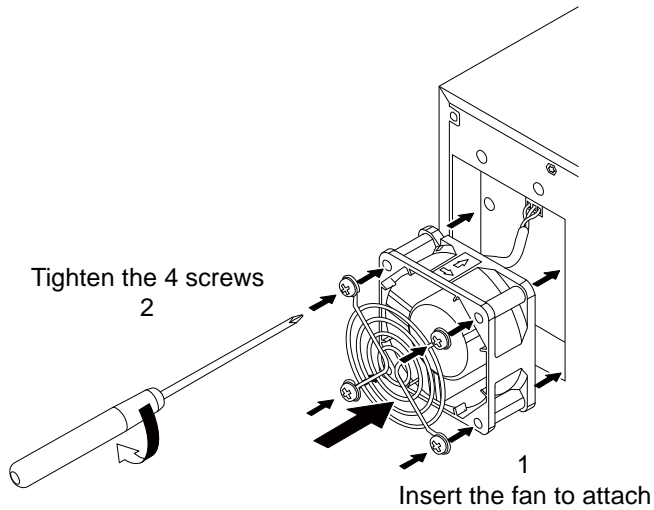

6. Attach the fan cover. (1)
Use a screwdriver to securely tighten (turn clockwise) the 2 removed screws. (2)
Fan replacement is now complete.

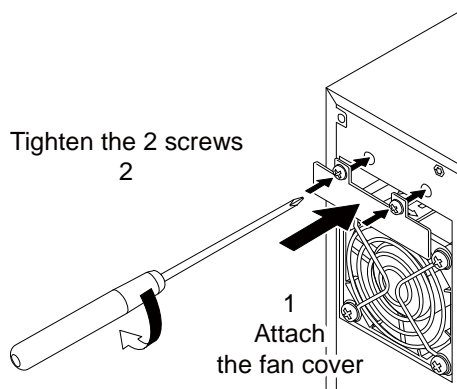

■ BA100R

Make sure that UPS doesn't connect to any AC inputs and the fan stops.

1. Use a screwdriver to loosen (turn counterclockwise) and remove the 2 screws on the fan cover above the fan on the back of the unit. (1)
Remove the fan cover. (2)

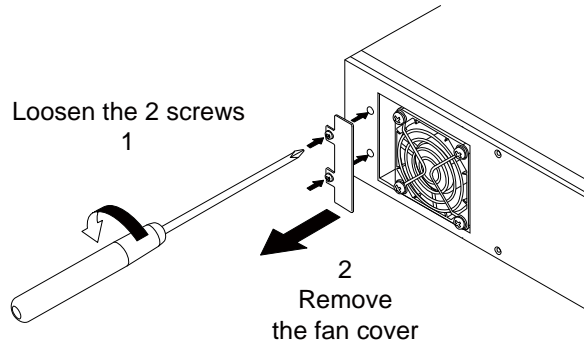

2. Use a screwdriver to loosen (turn counterclockwise) and remove the 4 cooling fan screws and the fan guard. (1)
Pull the fan toward you to remove it. (2)

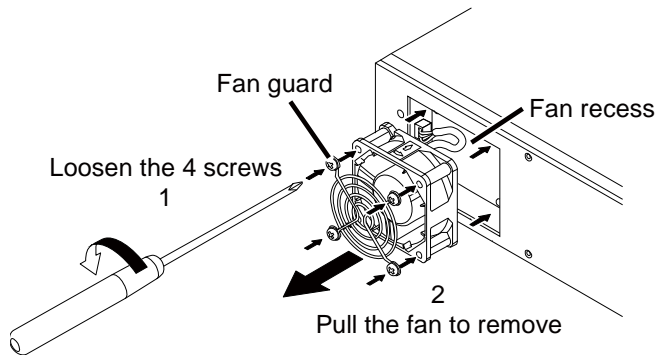

3. While pressing left on the tip of the fan connector (1, pull it toward you to disconnect it. (2)

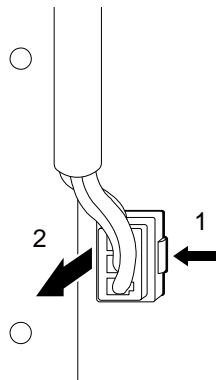

4 Replacing the fan

4-3 Replacing the fan

4. Insert the new fan connector until it clicks into place. (3)

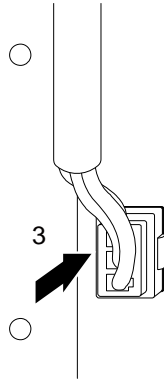

● Replacement fan

BA75T/BA100T/BA100R: Model BAF100R

5. Insert the fan and the fan guard into the unit's fan recess. (1)
Use a screwdriver to securely tighten (turn clockwise) the 4 removed screws. (2)
When doing so, make sure the cable does not become pinned under the fan's cover.

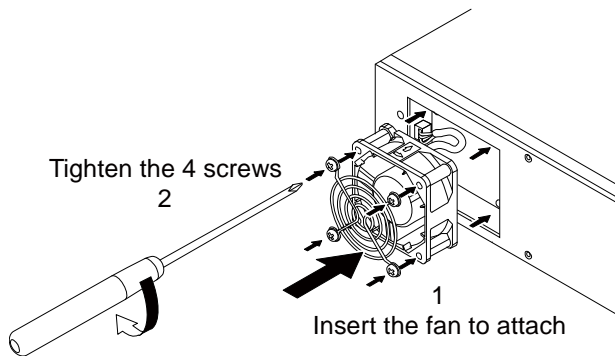

6. Attach the fan cover. (1)
Use a screwdriver to securely tighten (turn clockwise) the 2 removed screws. (2)
Fan replacement is now complete.

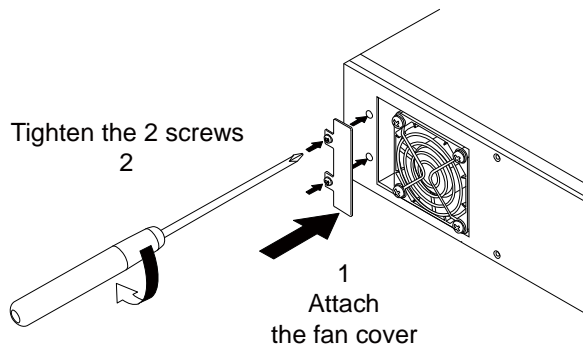

4-4 Cleaning

1. Cleaning the UPS

Moisten a soft cloth with water or detergent, squeeze it tightly, and wipe the product lightly.

Do not use chemicals such as thinner and benzene. (They cause deformation or discoloration.)

2. Removing dust from the input terminal block, and output terminal block of the UPS

Stop all the connected devices and the UPS and disconnect the AC input from the commercial power.

Then, remove dust with a dry cloth and make the connection again.

(For information on the connection procedure: see also "2-2 Connecting the equipment.")

5 To perform shutdown processing of the devices when a power failure occurs

5-1 The outline on the UPS monitoring software

“Simple Shutdown Software” and “UPS service driver” UPS monitoring software can be downloaded for free. The optional software, “PowerAct Pro”, is sold separately.

Choose which one to use based on the application.

5-1-1 UPS monitoring software function list

●: Supported, ---: Unsupported

Software title		General applications (Simple functions, standalone)		Network management applications (Advanced functions, network support)
		OS standard UPS service	Simple Shutdown Software (download)	PowerAct Pro (optional)
Functions				
Required options (sold separately)		---	---	PA01
Refer to the section number		Section 6	Section 5-2	Section 5-2
Software functions (Refer to the reference below.)	1. Auto shutdown	●	●	●
	2. UPS monitoring (operating status)	●	---	●
	3. UPS monitoring (data)	---	---	●
	4. Pop-up notification	●	---	●
	5. Shutdown when OS is inactive	---	---	●
	6. Schedule operation	---	---	●
	7. UPS setting change	---	---	●
	8. External command execution	●	●	●
	9. Event log save	---	---	●
	10. Data log save	---	---	●
	11. Coordinated shutdown	---	---	●
	12. Output receptacle control	---	---	●
	13. Redundant power supply support	---	---	●
	14. Remote UPS management	---	---	●
	15. Mail send	---	---	●
	16. SNMP management	---	---	●
	17. Telnet connection	---	---	●
	18. SYSLOG support	---	---	●



Additional Information

Explanation of software functions

	Function name	Description
1.	Auto shutdown	The computer can be shut down automatically when a problem occurs with the power supply.
2.	UPS monitoring (operating status)	The operating status of the UPS can be monitored (in Commercial Power Mode/Battery Mode).
3.	UPS monitoring (data)	Monitoring can be performed for input voltage value, connection capacity, battery capacity, etc.
4.	Pop-up notification	When a problem such as a power failure occurs, a pop-up window that shows the details of the problem can be displayed depends on OS.
5.	Shutdown when OS is inactive	Shutdown can be performed when the computer is in an inactive state. The operating status is retained at shutdown in inactive state, so operation details are not lost.
6.	Schedule operation	Schedule settings can be made for UPS stop/start.
7.	UPS setting change	UPS settings (beep ON/OFF, etc.) can be changed. (Items that can be set vary according to the UPS.)
8.	External command execution	By executing commands at shutdown, items such as application programs can be launched.
9.	Event log save	Information of events that occur on the UPS (power supply problems, setting changes, occurrences of failure, etc.) are saved as a log.
10.	Data log save	Data of input/output voltage value, connection capacity, etc. is periodically saved as a log (the save frequency can be set).
11.	Coordinated shutdown	When a problem occurs with the power supply, multiple computers connected to the UPS can coordinate to perform auto shutdown.
12.	Output receptacle control	The UPS output receptacles can be individually set to ON/OFF.
13.	Redundant power supply support	Two or more UPS can be connected to computers equipped with redundant power supply. Shutdown is not performed when a power supply problem affects only one of the units. Shutdown is performed only when a power supply problem occurs with both UPS, so the system's operating rate is improved.
14.	Remote UPS management	The UPS can be managed remotely from a computer on the network.
15.	Mail send	When a problem such as a power failure occurs, a notification email describing the problem can be sent to the system administrator.
16.	SNMP management	UPS management information can be sent to the SNMP manager.
17.	Telnet connection	Settings such as shutdown parameters can be made via the Telnet connection.
18.	SYSLOG support	UPS management information can be recorded in SYSLOG.

5 To perform shutdown processing of the devices when a power failure occurs

5-2 When using the UPS monitoring software

5-1-2 The supported OS of the UPS monitoring software

Refer to the list below to check the supported OS of the UPS monitoring software.

OS	Shutdown software
<ul style="list-style-type: none">• Windows 8.1• Windows Server 2012 R2 (※5)• Windows Storage Server 2012 R2• Windows 8• Windows Server 2012 (※3)• Windows Storage Server 2012• Windows Server 2008 R2 (※6)• Windows Storage Server 2008 R2• Windows Server 2008 (※6)• Windows Storage Server 2008• Windows 7• Windows Vista• Windows Server 2003 R2 x64 Editions• Windows Server 2003 x64 Edition (SP1)• Windows XP Professional x64 Edition (SP1)• Windows Server 2003 R2• Windows Server 2003 (SP1)• Windows XP (SP1/SP2/SP3)	PowerAct Pro (option)
<ul style="list-style-type: none">• Windows 8• Windows Server 2012• Windows 7• Windows Server 2008 R2• Windows XP• Windows Server 2003• Windows Server 2003 R2• Windows Vista• Windows Server 2008	Simple Shutdown Software (download)

The most recent version can be downloaded from our website

(https://socialsolution.omron.com/jp/ja/products_service/ups/support/download/download.html).

5-2 When using the UPS monitoring software

5-2-1 What is the PowerAct Pro

The optional “PowerAct Pro” UPS monitoring software allows you to perform shutdown processing of your PC when a power failure occurs.

- It is possible to shut down multiple computers on the network.
- You can perform desired operation by setting the automatic start/stop of the UPS based on the schedule setting.

Note: Ensure that your PC completes shutdown within the backup time after a power failure occurs. For the backup time, refer to “4-1-3 Estimated backup time”.

For more information, refer to the manual in the CD-ROM.

5-2-2 What is the Simple Shutdown Software

“Simple Shutdown Software” allows you to automatically shut down the PC when a power failure occurs. It can be downloaded from our website,

https://socialsolution.omron.com/jp/ja/products_service/ups/support/download/download.html

For more information, refer to the manual of this software.

5-2-3 How to connect

1. Connect the UPS to a computer.

Cable: Included connection cable (RS232C)

<BA75T/BA100T>

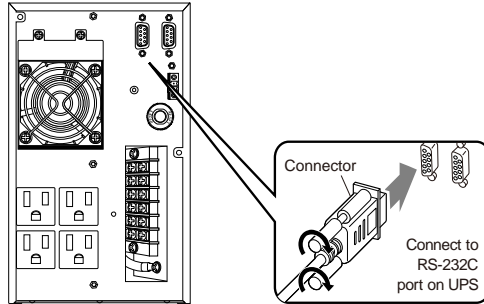

<BA100R>

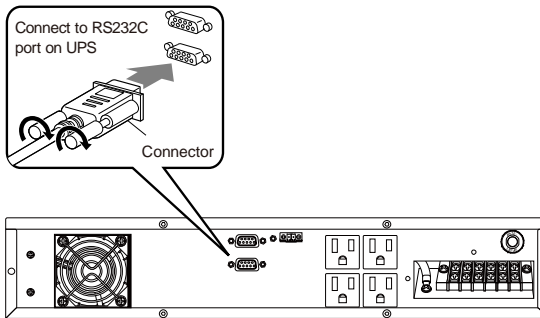

* When connecting 2 or more computers to the UPS (Only when using PowerAct Pro)

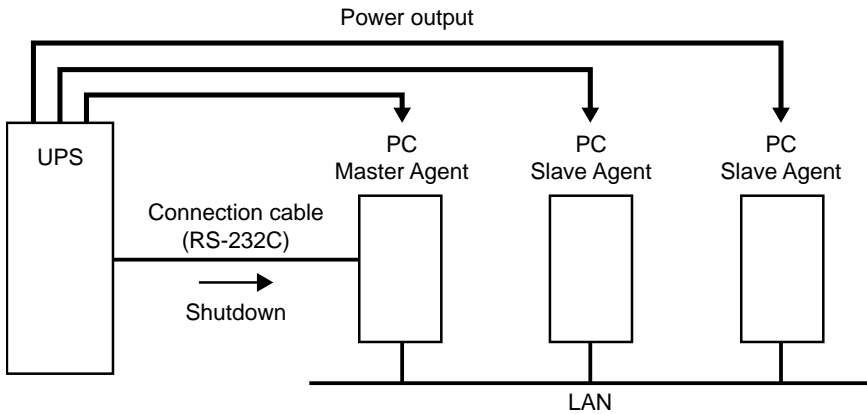

5 To perform shutdown processing of the devices when a power failure occurs

5-2 When using the UPS monitoring software

2. Install the "PowerAct Pro" or "Simple Shutdown Software" to the PC you want to shut down.

Note: Installation method:

For "PowerAct Pro", refer to the installation guide (for Windows) on the CD-ROM.

Refer to the manual for "Simple Shutdown Software".

Notes

The limitation on the commercial power stopped period when scheduled operation using the UPS monitoring software

- When performing scheduled operation in which the UPS is stopped and a device such as a breaker is used to stop the UPS at the same time that commercial power stops, specify a period of no more than 3 months (*) for the start of the next operation.
 - If you specify a period longer than 3 months (*), the internal timer is reset and the scheduled operation does not start. Note that this period reduces to approximately half when the battery is dead.
 - If a period of 3 months (*) is exceeded, you start operation by supplying commercial power and pressing the Start Switch. However, if the battery is dead, you may not be able to start operation.
In this case, replace the battery according to "4-2 Replacing the battery".
- * Note the time span will be shortened about half on the time to replace the battery.

When manually starting during the scheduled operation using the UPS monitoring software

- To manually start up this unit after it has been stopped by a scheduled operation, turn OFF the "Power" switch and turn it back ON again.

To stop the unit when it is in operation, turn OFF the "Power" switch.

Auto restart after OS closing processing using the UPS monitoring software.

When the power is restored while auto shutdown processing is being performed

- If a power failure occurs and then the power is restored while auto shutdown is still in progress, UPS output will stop temporarily after the set time elapses. After shutdown is finished, do not turn on the computer until the UPS has finished restarting.

6 Using the contact signal functions

6-1 Contact signal functions

Contact Signal

You can develop your unique system based on the following specifications to automate the process at a power failure. You can perform power-failure processing by allowing the system to detect the backup signal and also perform system shutdown processing by allowing the system to detect the Low battery level signal. Also, by inputting the backup stop signal from the system, you can stop the UPS with a sufficient battery level to prepare for the next occurrence of a power failure.

6-1-1 Type of Output signals

The UPS has 4 kinds of output signals.

The output circuit consists of an open collector circuit using a photo coupler (a kind of electronic switch).

Signals	Descriptions
Backup Signal output (BU)	Stays ON during backup operation at a power failure.
Low battery level signal output (BL)	Goes ON when the battery becomes weak during backup operation at a power failure.
Trouble Signal output (TR)	Goes ON when an internal failure of the UPS occurs or when the battery life counter expires.
Battery Replacement Signal output (WB)	Goes ON when the test determines that battery replacement is necessary due to deterioration or when the battery life counter goes off-scale.

6-1-2 Type of Input signals

The UPS has 2 kinds of input signals.

Signals	Descriptions
Input of the UPS Stop Signal (BS)	When the BS signal is ON (High), the output of the UPS is stopped after the time period specified in advance has elapsed. (Note 1).
Remote ON/OFF Signal	Remote ON/OFF signals can be used to start and stop the UPS, by using either an externally connected contact or the ON/OFF status of the open collector circuit. When signal is OFF, the UPS will be turned on. When signal is ON, the UPS will be turned off. In the factory settings, the UPS stops operation when this is short-circuited. In addition, it is necessary to turn on the "Power" switch of UPS to use this function (Note 2).

Note 1: BS Delay Time:

You can set the amount of time between when the BS signal is received and when the output of the UPS is stopped (See also "3-5-2 Settings").

You can stop the output of the UPS by inputting the voltage signal (HIGH) that lasts at least 10 seconds from the outside.

Note 2: Connection terminals are at contact signal port pins 6, 7 and the remote ON/OFF port (See also "3-1-4 Setting Switch").

6 Contact signal functions

6-1 Contact signal functions

6-1-3 Contact signal port (female D-SUB 9 pin)

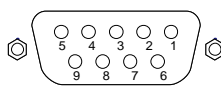
Pin assignment	Pin number	Item
 <p>Front view</p> <p>Screw size: inch screw #4-40 UNC</p>	1	Battery LOW signal output (BL)
	2	Trouble signal output (TR)
	3	Backup stop signal input (BS)
	4	NC
	5	COMMON(COM)
	6	Remote ON/OFF input (-)
	7	Remote ON/OFF input (+)
	8	Backup signal output (BU)
	9	Battery Replacement Signal output (WB)

Note 1: When fixing the D-SUB (9 pin) connector by screw, please tighten manually without using the electric driver.

6-1-4 Remote ON/OFF port

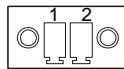
Pin assignment	Pin number	Signal name
 <p>Front view</p> <p>Screw size: Inch screw #4-40 UNC</p>	1	Remote ON/OFF (+)
	2	Remote ON/OFF (-)

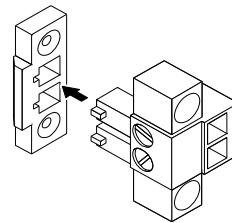

6-1-5 Contact Signal ratings

- Signal output (BL, TR, BU, WB)

Photo coupler ratings

Applicable voltage: 50VDC or less

Maximum current: 50 mA

- Remote ON/OFF

Voltage between terminals: 5 VDC

Current when closed: 10 mA max.

- UPS Stop Signal input (BS)

Input voltage: HIGH(ON) 5 to 15 VDC

LOW(OFF) 0.5 VDC or less

Input current: 2 to 18 mA

6-1-6 Contact Signal circuit

- Signal output (BL, TR, BU, WB)
- UPS Stop Signal input (BS)

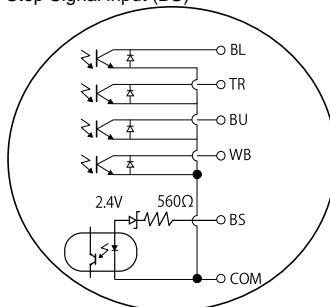

- Remote ON/OFF

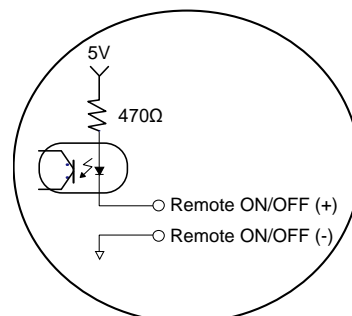

6-1-7 Example of the use of the Contact Signal circuit

- Example of BU signal output circuit and the connected circuit

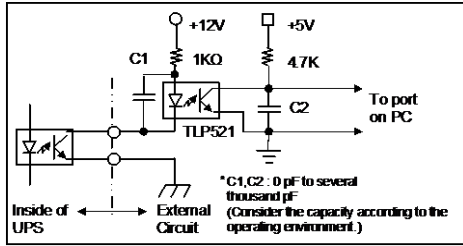

- Example of BS signal input circuit and the connected circuit

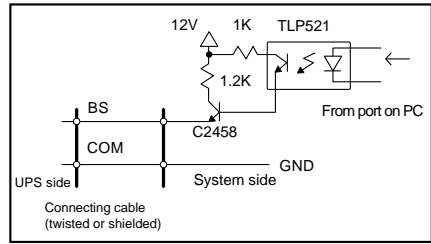

- Remote ON/OFF circuit

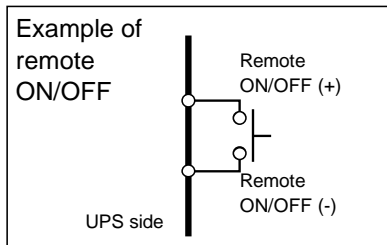

6-1-8 Precautions and notes for the use of the Contact Signal

Notes

When connecting a device such as a relay that generates counter electromotive force to the signal output circuit, connect diodes that prevent counter electromotive force to both ends of the relay.

Explanation:

- When power is restored after the unit stopped automatically during a power failure, the unit automatically restarts and supplies power. If you do not want to start the connected devices, turn OFF their switches or set the auto startup setting after recovery from power failure ("Setting" switch 2) to ON (Auto startup is not performed).

7 Troubleshooting

Perform the checks shown below if the unit is operating abnormally.

If the unit continues to operate abnormally, please contact our Electronic Systems & Equipments Customer Support Center.

Problem	Check and remedy
The LED does not appear when the AC input is connected to commercial power and the "Power" switch is turned ON.	<ol style="list-style-type: none"> 1. Make sure the AC input is securely connected to commercial power. 2. AC input overcurrent protection is activated and power is cut. <ul style="list-style-type: none"> ● If the black INPUT PROTECTION button pops up, there are too many connected devices or there was a short-circuit with the connected devices. Disconnect all the connected devices, press the black INPUT PROTECTION switch (overcurrent protection switch), and turn on the "Power" switch. ● If the status indicator does not display properly after you perform the above operation, there is a problem with the unit. <p>(See "3-4 Interpreting beeps and displays".)</p>
Backup is not possible. The computer stops when a power failure occurs.	<p>The battery may not be fully charged.</p> <p>Perform the test after charging the battery for at least 8 hours. The battery can be charged just by connecting the AC input to a wall outlet. The "Power" switch can be either ON or OFF.</p>
Backup is performed too frequently. Frequent switching is performed although a power failure does not occur. You hear the sound of switching.	<p>Variations (decrease) in the input power occur frequently. Or, noise may be included that significantly distorts the voltage waveform of the input power.</p> <ul style="list-style-type: none"> ● Try and check what happens when connecting the unit to a different wall outlet (commercial power) located some distance away from the device consuming a large amount of power. ● This problem may occur also when you connect many devices to a plug strip or extension cord connected to the UPS if it is a long or thin cable.
Does not turn ON when "Power" switch is pressed.	<p>The unit does not start up when the input power supply voltage/frequency is abnormal. (The status indicator displays "H-", "-H", "L-", "-L", "HH" or "LL".) Check the voltage and frequency of the input power supply.</p> <p>See also "3-4 Interpreting beeps and displays".</p>
The display is abnormal. ● The display is unstable. ● White lines occur. ● Noise increases.	<p>The probable cause is noise that occurs inside the UPS.</p> <ul style="list-style-type: none"> ● Ground all devices connected to the UPS. Connect them to a wall outlet (commercial power) for 3-pin plugs or connect their Grounding Terminal to the Grounding Terminal of a wall outlet. ● This problem may occur when power cords are long or placed closely or when the UPS and devices to be backed up are placed closely. Rearrange them. ● If the UPS or devices connected to the UPS are contained in a metal rack, attempt to ground the rack itself.
The battery replacement lamp lights blinks, and the beeper sounds at 2-second intervals.	<p>Judged as battery deterioration by self-diagnosis test. Replace the battery as only the short backup operation time is available. Alternatively, Battery life counter went off-scale. The life of the battery has expired. Replace the battery.</p> <p>See also "4-2 Replacing the battery".</p>
The status indicator shows "UL", and the beeper sounds at 0.5-second intervals.	<p>There are too many connected devices. Reduce the number of connected devices until "Un" is displayed on the status indicator.</p>
The status indicator blinks "LU", and the beeper sounds continuously	<p>Output stopped due to exceeded connection capacity.</p> <p>Turn OFF all power to the unit and connected devices, and reduce the number of connected devices. Then, turn the power to the unit and connected devices back ON and check whether "Un" is displayed on the status indicator. See also "3-4 Interpreting beeps and displays".</p>

8 Note of Chinese

不间断电源 (UPS)

使用注意事项

OMRON

承蒙惠购本公司的不间断电源 (以下简称 UPS)，谨致谢意。
使用前，请务必仔细阅读本文的“使用注意事项”。

1. 前言

UPS 的用途

- 本装置的设计和生产目的是为了用于计算机等 FA、OA 设备。
请勿用于要求高度可靠性或安全性的下述用途。
- 直接关系到人类生命安全的医疗设备
- 可能导致人体受伤的用途。(直接影响飞机、船舶、铁路、电梯等运行、运转、控制等用途)
- 车载、船舶等可能随时发生振动的用途。
- 发生故障后可能对社会、公共财物造成重大损失或影响的用途。
(主要的电子计算机系统、中枢通信设备、公共交通系统等)
- 相当于上述用途的设备
- 关系到人类生命安全、可能对维护公共职能带来重大影响的装置等在实现系统多元化、紧急备用发电设备等的维护及管理方面尤其需要慎重。
- 使用时请务必严守使用说明书中所记载的使用条件、环境要求等。
- 尤其在要求高度可靠性的重要系统上使用，请务必向欧姆龙自动化 (中国) 有限公司进行咨询。
- 请勿对装置进行改造或加工。

免责声明

即使是因使用本公司产品而发生的事故，本公司对于包括装置·连接设备·软件的异常、故障所造成的损失及其他次生损失的所有损失赔偿概不负责。

其他



- 我们在首页记述了安全注意事项，请务必在仔细阅读后正确使用。
- 将本装置转让、转卖于第三方时，请务必连同本装置附带的所有资料等一并转让。
本装置符合附件资料等所记载的条件标准。
- 说明书中记载了相关安全事项等。请务必确认相关内容后再开始使用。
此外，万一使用说明书遗失，请联系欧姆龙自动化 (中国) 有限公司。
- Windows 是美国微软公司在美国及其他国家的注册商标。
- 同时，所记载的各公司名称、各公司产品名称均为各公司的商标或注册商标。

2. 安全注意事项



为了确保安全使用，如下就相关重要事项进行说明。



设置或开始使用前请务必仔细阅读。

- 本使用说明书中的相关安全符号及其含义如下所述。

	危险	表示操作失误可能会导致人员伤亡的内容。
	注意	表示操作失误可能会致残、导致物质损失的内容。

- ※ 所谓物质损失，是指房屋、家产以及家畜、宠物相关的连带损失。

 : 表示禁止 (不可发生的行为)。例如  表示禁止擅自拆卸。

 : 表示强制 (必须的行为)。例如  表示必须进行接地连接。

此外，即使是注意事项中所记载的内容，也可能根据不同的状况而导致严重后果。

总之，这里记述均为重要内容，请务必严守。

危险 (产品用途)

不得将本装置用于下述要求高度可靠性或安全性的用途。

※ 本装置的设计和生产品目的是为了用于计算机等 FA、OA 设备。

- 直接关系到人类生命安全的医疗设备或系统。
- 直接关系到人身安全的相关用途。(例如：车辆、电梯等的运行、运转、控制等)
- 发生故障后可能对社会、公共财物造成重大损失的用途。(例如：主要的电子计算机系统、中枢通信设备等)
- 相当于上述用途的设备。



这是一个 A 类信息技术设备。当此设备用于家庭环境中的功率时可能会造成干扰波。用户在这种情况下应采取适当的措施。VCCI-A

注意 (设置·连接时)

搬运时应注意重量分配平衡，并放置于安全稳定的场所使用。

- 一旦翻倒或掉落可能导致受伤。
- 本机的质量，BA75T/BA100T 是 12.5 公斤，BA100R 是 13 公斤。
- 万一掉落时，请立即停止本装置的使用，并委托相关单位进行检查和维修。维修事宜请向 欧姆龙自动化(中国)有限公司 客户服务中心维修部 咨询。



包装用塑料袋请放置于幼儿无法触及的场所。

- 万一幼儿蒙住头部则可能导致呼吸困难的危险。



⚠ 注意 (设置·连接时)

本装置的“AC 输入”插头必须连接至符合产品规格的额定输入电压 (AC100V、110V、115V、120V)、频率 50/60Hz 的电源插座。

- 如果连接至不同电压、频率的电源插座，则可能引起火灾。
- 可能导致本装置发生故障。



发现异常 (异常声响、异味) 时，应关闭“电源”开关停止输出，然后从电源插座上拔掉“AC 输入”插头。

- 为了确保安全，连接设备需要维修保养等场合也应按上述标准执行。



不得连接烘干机、部分电磁阀等电流只在交流电源半周期内流动的半波整流设备。

- 可能因过电流而导致不间断电源发生故障。



安装输入电缆时请一定按照指定的连接方法。

在停止初级侧的电源状态下，进行该装置的交流输入端的连接操作。

- 连接到端子块电缆，应采用满足 UPS 的输入电流规格。否则有触电，有漏电的危险。



应正确进行接地连接。

- 若未执行接地连接，则可能因故障或漏电而导致触电事故的发生。



不得擅自拆卸、维修、改造。接地端子连接市电时，进行接地连接。

- 可能有导致触电、火灾的危险。



不得设置于指定以外的方向。

- 一旦翻倒或掉落可能导致受伤。
- 若设置于指定以外的方向，电池发生漏液时则无法发挥保护作用。



不得在超出产品标准运转环境温度的场所使用。

- 电池快速老化，有火灾的危险。
- 可能导致本装置发生故障、操作失误。



使用保管环境不得超出规格范围。

不得在以下场所执行设置或保管。

- 不得在湿度低于 10%/湿度高于 90% 的场所保管。
- 不得在周围温度低于 0°C/周围温度高于 40°C 的场所使用。(不结露)
- 不得在湿度低于 25%/湿度高于 85% 的场所使用。
- 无缝隙的柜子等封闭性场所 / 存在易燃性气体或腐蚀性气体的场所、阳光直射的场所、灰尘极多的场所、产生振动或施加冲击力的场所、室外等。
- 可能导致火灾等情况发生。



不得连接超出本装置输出容量的设备。

可通过插线板等增设连接设备，但这种情况下不得连接超出插线板等设备电流容量的设备。

- 本装置检测到过载，停止输出。
- 电源板的配线发热，可能导致火灾。



不得在夹住或硬弯曲电缆的状态下使用。不得在捆住电缆的状态下使用。

- 可能因电缆损伤或发热而发生触电、火灾的危险。
- 若电缆上发现伤痕，请立即停止本装置的使用，并委托相关单位进行维修。维修事宜请向 欧姆龙自动化 (中国) 有限公司 客户服务中心维修部 咨询



⚠ 注意 (设置·连接时)

同一捆包的所有附件仅限本装置使用。请勿在其他设备上使用。

- 为了确保设备的安全使用，请务必遵守。



吸排气口不得堵塞。(前面、背面以及侧面)

- 内部温度上升可能导致本装置发生故障、电池老化。
- 请设置于距离墙面 5cm 以上的场所。



设置于机架上使用时，应将本产品设置于机架的最下层。

- 一旦掉落可能导致受伤。



安装时应使用附带的螺钉。

- 安装机箱时如果使用附带品以外过长的螺钉，则可能会损坏内部。
- 如果使用附带品意外的螺钉，由于强度不够可能会有掉落的风险。

**⚠ 注意 (使用时)**

不得沾湿、浇水。

- 可能会导致触电、火灾。
- 万一沾水时，请立即停止本装置的使用、拔掉 AC 输入电缆，并委托相关单位进行检查和维修。
维修事宜请向 欧姆龙自动化(中国)有限公司 客户服务中心维修部 咨询。



已达到使用寿命的电池应立即更换、或停止本装置的使用。

- 继续使用可能会因漏液而导致火灾、触电事故的发生。

环境温度	平均寿命
25°C	5 年
30°C	4 年

※以上为标准使用条件下的平均寿命，非确定值



“AC 输入”插头、电源输出插座上的灰尘应及时用干布擦去。

- 灰尘长期附着可能会导致火灾的发生。



不得在封闭性场所、或盖上外盖的状态下使用。

- 可能会导致异常发热或火灾。



发现异常声响或异味、冒烟、内部溢出液体现象时，应立即切断本装置的“电源”开关，并从电源插座上拔去“AC 输入”插头。

- 若在这种状态下继续使用，则会导致火灾的发生。
- 若发生这种状况，请立即停止使用，并拔去 AC 输入插头，然后委托购买产品的店铺、或 欧姆龙自动化(中国)有限公司 客户服务中心维修部 进行检查和维修。
- 使用中发生异常时，请从电源插座上拔去“AC 输入”插头后待机。



⚠ 注意 (使用时)

不得触摸从内部溢出的液体。

- 有导致失明、烧伤的危险。
- 若接触到眼睛或皮肤，请立即用水充分冲洗，并接受医生的诊治。



机箱上面不得放置其他物品、也不得有重物落下。

- 可能因机箱的歪斜或损坏、内部电路故障而导致火灾的发生。



即使因内部控制电路功能发生故障或操作错误而停止，依然可以提供向连接设备供电的旁路输出电路。

- 即使前面板显示全部消失，输出依然会继续。
- 前面的输出电源开关将无法执行 ON/OFF 切换。
想要停止输出时，请切断商用电源的供给源、或从电源插座上拔去 AC 输入插头，则请关闭本装置背面的输入过电流保护开关“INPUT PROTECTION”



若输入插头在运转状态下脱落，绝对不得触摸输入插头的金属部位。

- 有触电的危险。
- 本装置单机漏电流在安全标准（漏电：1mA）以下，但连接设备的漏电增加，故请绝对不要触摸输入插头的金属部位。
- 本装置在运转状态时，无论运转时间长短，均会通过内部电路在输入插头的金属部位产生电压。



进行连接设备保养时，必须在关闭本装置的“电源”开关、并拔掉“AC 输入”插头的状态下执行。

- 本装置的电源输出在不间断电源（UPS）为运转状态时，即使拔掉“AC 输入”插头也不会停止输出，将会以插座作为供电源进行供电。



不得擅自拆卸、维修、改造。

- 可能有导致触电、火灾的危险。



不得触摸从内部溢出的液体。

- 有导致失明、烧伤的危险。
- 若接触到眼睛或皮肤，请立即用水充分冲洗，并接受医生的诊治。



不得将本装置扔至火中。

- 本装置内置铅酸蓄电池，故可能会发生电池爆炸、稀硫酸泄漏。



不得将金属物体插入不间断电源（UPS）的“电源输出”插座。

- 可能会导致触电



不得将金属物体插入电池连接口。

- 可能会导致触电。



更换作业应在稳定且平坦的场所执行。

- 请小心托住以防电池掉落。
- 可能因掉落而导致受伤、或因漏液（酸）而导致烧伤等危险。



不得使用指定范围以外的更换电池。

- 可能导致火灾的发生。



 **注意 (使用时)**

不得在有易燃性气体的场所更换电池。

- 连接电池时会产生火花飞溅现象，可能会导致爆炸或火灾。



电池发生漏液时不得触摸泄漏的液体 (稀硫酸)。

- 有导致失明、烧伤的危险。
- 若接触到眼睛或皮肤，请立即用水充分冲洗，并接受医生的诊治。



不得擅自对电池进行拆卸、改造。

- 不得触摸泄漏的稀硫酸，否则可能会导致失明、烧伤等。



小心电池掉落、不得对其施加强大冲击力。

- 可能会发生稀硫酸泄漏。



不得通过金属物体使电池短路。

- 可能会导致触电、起火、烧伤等。
- 即使是使用后的电池，其内部依然会残存电能。



不得将电池扔至火中、或将其毁坏。

- 电池可能会发生爆炸，稀硫酸可能会发生泄漏。



不得将新旧电池混合使用。

- 可能会发生稀硫酸泄漏。



注意事项

购买后请尽快充电。

- 购买后若长时间搁置，则可能导致电池性能退化以致无法使用。
- 将本装置的“AC 输入”插头插入市电电源即可对电池进行充电。

由低温场所移动至温暖场所后，请搁置数小时后再开始使用。

- 突然移动至温暖场所后会有水分附着（结露），若直接通电则可能导致故障发生。

请做好数据保护和系统冗余等意外情况的应对措施。

- 不间断电源（UPS）的输出可能会由于故障而停止输出。

保管本装置时，请对电池进行产品标准充电时间以上的充电后再关闭“电源”开关。

- 电池即使不使用也会在内部自然放电，长时间搁置后会呈现过放电状态。由此导致后备时间缩短、以致无法使用。
- 需长期保管时，推荐环境温度为 25°C 以下。

保管温度在 25°C 以下时请在 6 个月以内、40°C 以下时请在 2 个月以内将本装置的“AC 输入”插头连接至达到产品标准充电时间以上的电源插座。

- 保管期间请关闭本装置的“电源”开关。

请勿在后备式运转状态下将“AC 输入”插头插入本装置的“电源输出”插座。

- 可能导致本装置发生故障。

请勿将页式打印机（激光打印机等）连接至本装置。

- 在商业化操作时，频繁出现连接容量过载的情况，有可能导致输出与输入功率相同（旁路回路运行）。
- 页式打印机的峰值电流较大，可能会被检测到连接容量过载。

将本装置用于线圈、电机等感应性设备上时，请务必事先检查运转状态后再开始使用。

- 有些种类的设备可能会因冲击电流等影响而导致本装置无法正常运转。

将本装置与自备电源等电源频率较大变动的设备配套使用时，请务必事先检查运转状态后再开始使用。

- 当发电机的输出电压和频率在输入电压和单元外的频率范围外时，将进行后备运行。

请勿将本装置放置于阳光直射的场所进行保管。

- 可能会因温度上升而导致内置电池快速老化以致无法使用。

切断商用电源前，请先关闭本装置的“电源”开关。

- 切断商用电源后，即会进入后备式运转。后备式运转的频率越高，表示电池使用寿命可能越来越短。

将本装置用于线圈、马达等感应性设备上时，请务必事先检查运转状态后再开始使用。

- 有些种类的设备可能会因冲击电流等影响而导致本装置无法正常运转。

请勿执行耐压试验。

- 电源输入线中装有浪涌吸收器，若执行耐压试验则会导致浪涌吸收器受损。
- 执行绝缘电阻试验时，请在 DC250V 范围内执行。

请注意避免本装置输出电路之间、以及输出电路接地上发生短路。

- 可能导致本装置发生故障。
-

将本装置转让、转卖于第三方时，请务必连同本装置附带的所有资料等一并转让。本装置符合附件资料等所记载的条件标准。

- 本说明书中记载了相关安全事项等。请务必确认相关内容后再开始使用。
此外，万一使用说明书遗失，请在本公司网站下载使用。

请勿使用会因产品标准切换时间内的瞬间停电而发生异常的设备。

- 后备式、在线互动式不间断电源（UPS）在停电时进入后备式运转需要切换时间。在要求具有……高度电源稳定性的设备上使用时，可能会因输出电压的瞬间变动而导致连接设备停止运转。切换时间相关内容请参照使用说明书。

若在“输出 100V 模式”范围以外使用本装置，则请务必事先检查运转状态后再开始使用。

- 后备式运转时，输出（正弦波）的最大电压值（峰值电压）有时会低于商用电源下运转时的数值。因此，根据不同的连接设备，有时可能无法正常运转。

本产品中使用了铅酸蓄电池（铅蓄电池）。

- 铅酸蓄电池需要进行回收。使用后的电池请寄至以下地址。

欧姆龙自动化（中国）有限公司
<http://www.fa.omron.com.cn/>

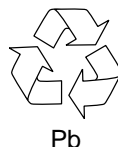

讲解

关于日常运转方法

- 本装置的“电源”开关既可始终为开启状态（运转状态），也可在每次停止连接系统运转时切换为关闭状态。请用户采用便于使用的方法即可。长期不使用连接设备时，建议关闭“电源”开关。
- 将本装置的“AC 输入”插头插入电源插座即可对电池进行充电。
本装置的“AC 输入”插头请务必连接至符合产品规格的额定输入电压、频率 50/60Hz 的电源插座。

关于后备式运转的退出

- 长时间停电后，电池会发生放电现象，来自本装置的电源输出将会停止。请在本装置尚处于供电状态下正常退出计算机系统（保存数据等操作）。

关于重启

- 若电池在停电中发生放电现象，本装置将会停止运转。之后若停电等电源异常恢复正常，本装置将会自动重启并重新开始供电。无需运转连接设备时，请关闭本装置的“电源”开关、或连接设备的开关。

关于自动关机软件的排程运转

- 若想在停止本装置运转的同时、执行通过断路器等停止商用电源供电的排程运转，请将开始下次运转的间隔时间设定为 3 个月以内。超出 3 个月时，内部定时器将会被复位，故不会按排程设定开始运转。
同时，该期间若电池寿命缩短则会减半。
超出 3 个月，通过供电和开启“运转”开关即可开始运转，但若电池已达到使用寿命时，则可能无法开始运转。这种情况下，请按使用说明书所记述的方式更换电池。

请采取对策，以防数据保护或系统冗余化等无法预测的事态发生。

- 不间断电源 (UPS) 有时会因内部电路的故障而停止输出。

关于自动关机软件的排程运转

- 采用排程运转时，若在排程停止期间停止商用电源的输入，那么开始下次运转的间隔时间最多请设定为 1 个月。
停止商用电源输入期间，定时器通过内置电池执行操作。
定时器停止时，则不会按排程设定开始运转。

关于通过自动关机软件使停止中的排程开始运转

- 在排程停止期间开始运转不间断电源时，请关闭电源开关一次，然后再重新开启电源开关。
通过手动方式启动不间断电源。

关于通过关机软件退出 OS 后的自动重启

- 在特定计算机*1 上，停电时会发生通过自动关机软件退出 OS、然后计算机立即重启的现象。
这种情况可能会导致不间断电源在计算机重启中或启动后停止运转，以致文件或硬盘受损。
将计算机 BIOS 设定内的 POWER MANAGEMENT 改为 Disable (无效) 即可防止此现象的发生。

*1) 特定计算机：此现象已在 MICRON 生产的 Millennia MME 上得到确认。

- 计算机无法自动重启时，请在计算机的 BIOS 设定中选择“输入电源恢复后的系统启动”设定项目 (例：Restore on AC/Power Loss) 并将其设定修改为“输入电源恢复后启动系统” (例：Power On)。另外，根据所使用的计算机的不同，BIOS 的设定方法或显示项目有所差异。
请查看所使用的计算机使用说明书、或联系计算机支持中心。
- 若您正在探讨输入电源恢复后使计算机自动重启的系统课题，则请选择满足以下条件的计算机。
关于通过输入电源进行供电时的计算机运转状况，请查看计算机使用说明书、或联系计算机支持中心。
【条件】
通过输入电源供电时，计算机无需开启自身的电源开关即可启动。
- 停电时，若刚退出即恢复供电，不间断电源则会自动启动并开始供电。无需运转连接设备时，
请关闭设备的电源开关。
- 使用附带的自动关机软件后，还可设定为无需自动重启。

9 References

9-1 Specifications

Model		BA75T	BA100T	BA100R
Method	Operation method	Full-time inverter supply method (Automatic Switching)		
	Cooling method	Forced air cooling		
Input	Rated input voltage	100/110/115/120 VAC		
	Input voltage range	70±2 to 146±2 V AC (with less than 90% connection load)		
		80±2 to 146±2 V AC (with 90% or more connection load)		
	Frequency	Synchronous mode	50/60 Hz±5.5 Hz	
		Asynchronous mode	39 Hz to 71 Hz	
	Input Maximum current *1	9.6A	13A	
	Phase	Single-phase, two-wire (grounded)		
Input protection	Non Fuse Breaker (10A)	Non Fuse Breaker (15A)		
AC input terminal	Terminal block			
Output	Rated output capacity	750 VA/600 W	1000 VA/800 W	
	Voltage	Commercial operation	100V mode: 100VAC±2%, 110V mode: 110VAC±2% 115V mode: 115VAC±2%, 120V mode: 120VAC±2%	
		Backup operation	100V mode: 100VAC±2%, 110V mode: 110VAC±2% 115V mode: 115VAC±2%, 120V mode: 120VAC±2%	
	Frequency	Synchronous mode	Commercial operation: Synchronized with input frequency Backup operation: 50/60 Hz±0.1 Hz Frequency selection: Automatic selection when UPS start	
		Asynchronous mode	Commercial operation: 50/60 Hz±0.5% Backup operation: 50/60 Hz±0.5%	
	Waveform	Commercial operation	Sine wave	
		Backup operation	Sine wave	
		Distortion rate	6% max. (Rectified load, at rated output) 3% max. (Resistance load, at rated output)	
	Phase	Single-phase, two-wire (grounded)		
	Output receptacle	NEMA 5-15R x 4 / Terminal block		
Battery	Type	Sealed lead battery		
	Voltage / Capacity x Quantity	12 V / 7.2 Ah x 2		
	Backup time (25°C, initial characteristics)	6 min. or more (525W)	5 min. or more (700W)	
	Charging time	8 hours		
Battery life	Ambient temperature 25°C	Expected life: 5 years		
Envi- ron- ment	Operating environment temperature/ humidity	0 °C to 40 °C, 25 to 85%RH with no condensation		
	Storage temperature	-15 °C to 40 °C, 10 to 90%RH with no condensation		
	Safety standard	UL1778		
	Disturbance voltage / Radiated interference field strength	VCCI Class A		
	Internal power consumption (normal/maximum)	91W (*2) / 146W (*3)		
	Noise	50 dB		
Dimensions (W x D x H)	128 mm x 345 mm x 215 mm		438 mm x 315 mm x 85 mm	
Weight of unit	Approx. 12.5 kg		Approx. 12.5 kg	
			Approx. 13 kg	

*1: Minimum input voltage 70V for 100V mode with 90% load

*2: Rated load/ Rated input voltage/ When fully charged

*3: Rated load/ Rated input voltage/ When battery charge current is at maximum

Note: About ECO mode, see p. 39.

9-2 Dimensions

* Unit: mm/ Tolerance: ± 2 mm

● BA75T/BA100T

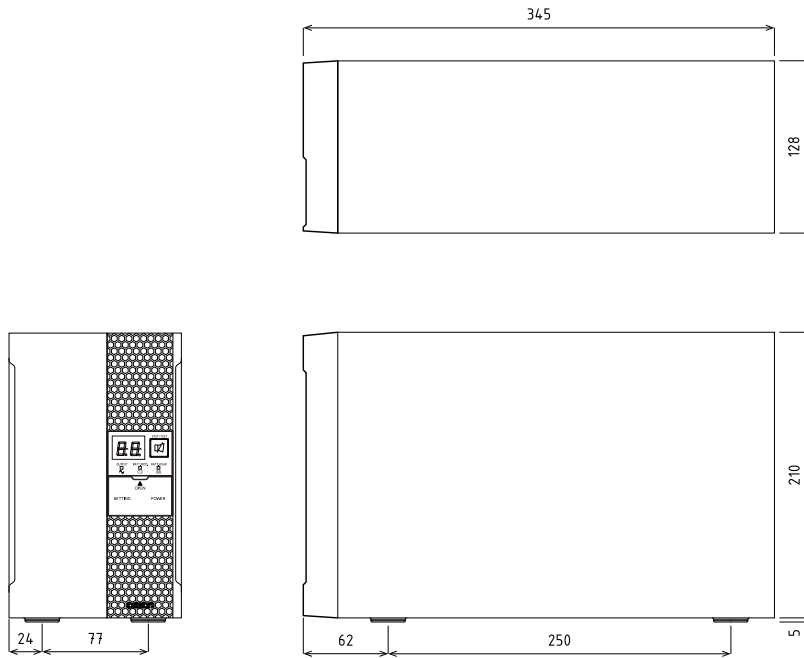

● BA100R

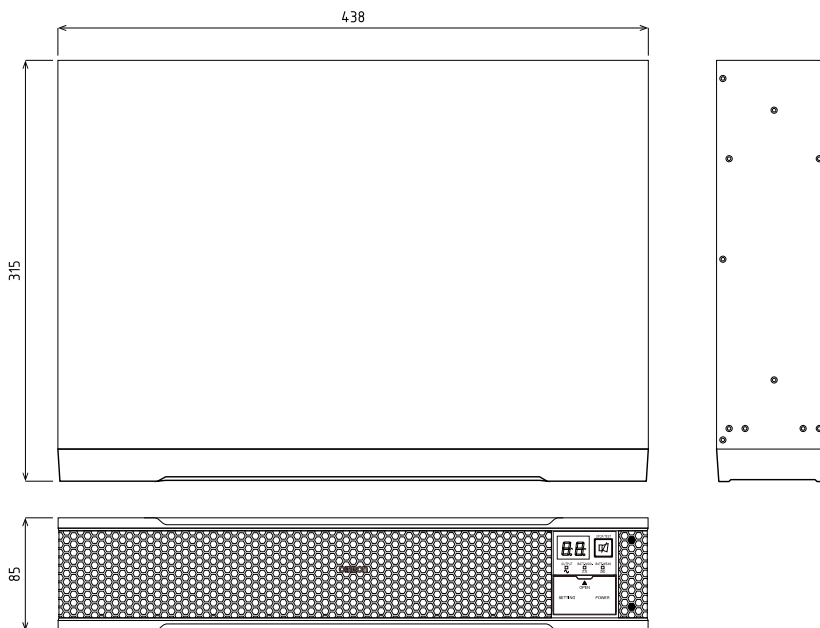

* Unit: mm/ Tolerance: ± 1 mm

● Upright stand for BA75T/100T (BAP100T)

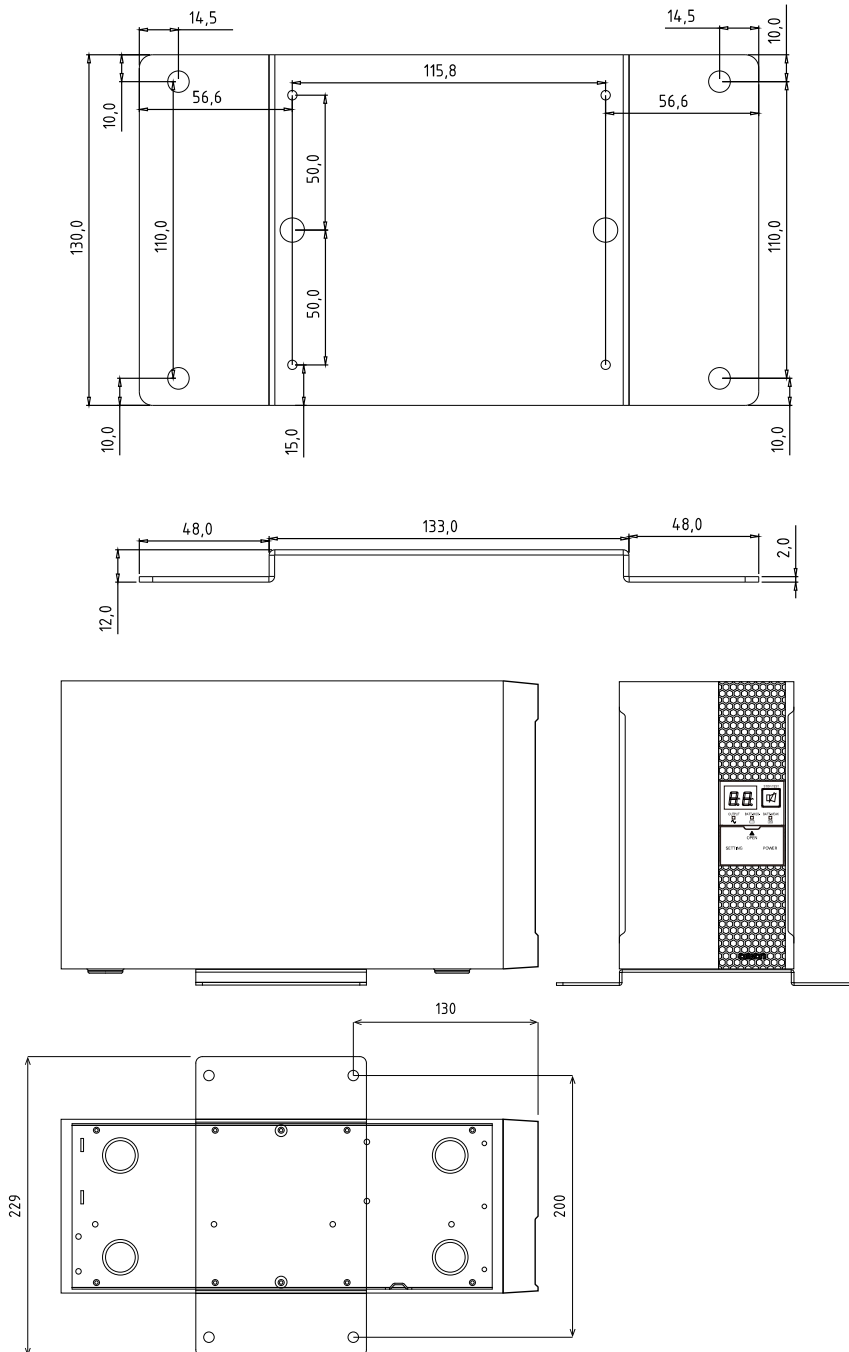

9 References

9-2 Dimensions

● Upright stand for BA100R (BAP100R)

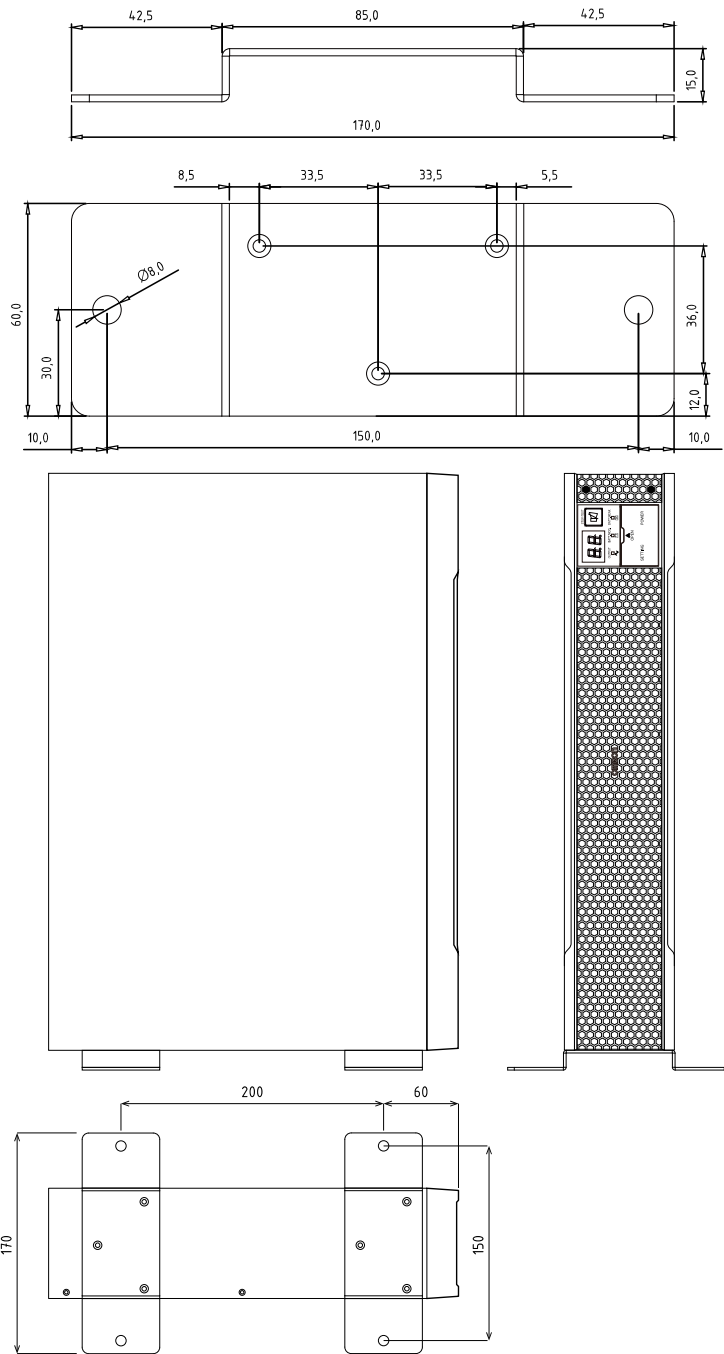

● Rubber feet

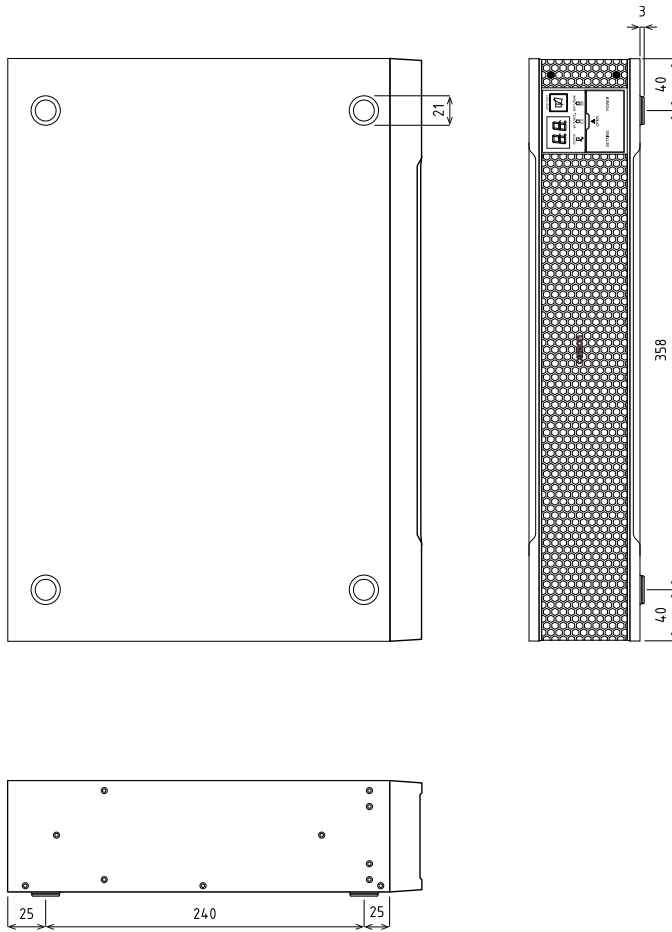

9 References

9-2 Dimensions

● Using Ear brackets (BAP100RS)

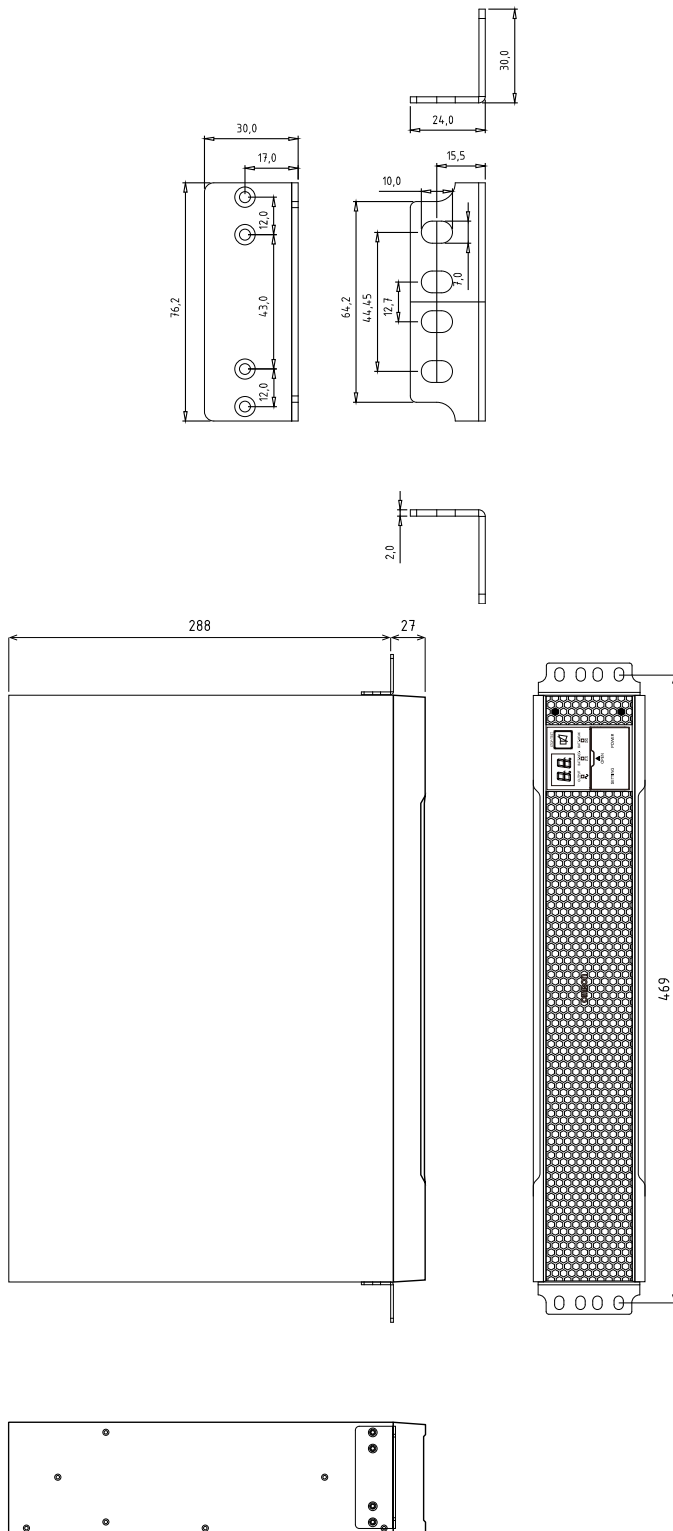

9-3 Battery life

■ Battery has a limited life span.

Periodic checks of the lead battery used in the battery unit are required due to the battery limited lifespan. For the battery checking method, refer to "4-1 Checking the battery". Battery replacement is recommended before the battery is expired.

● Battery life

(The following is expressed based on the battery's trickle life, the service life of a battery under the condition where low-frequent (once or twice a month) rechargings and dischargings are performed.)

Battery type	Expected battery life (Ambient temperature 40°C)	Expected battery life (Ambient temperature 30°C)	Expected battery life (Ambient temperature 25°C)	UPS Series
Long-life battery	1.7 years	3.5 years	5 years	BA series

Basically, the ambient temperature have a high influence on the battery life.

■ The periodic recharges are required even if the battery is stored.

The battery self-discharges even if the UPS is not used (i.e., leaving the battery not charged), and it deteriorates the battery. In the worst case, the battery may become unusable.

● Example of the storing condition and recharging frequencies

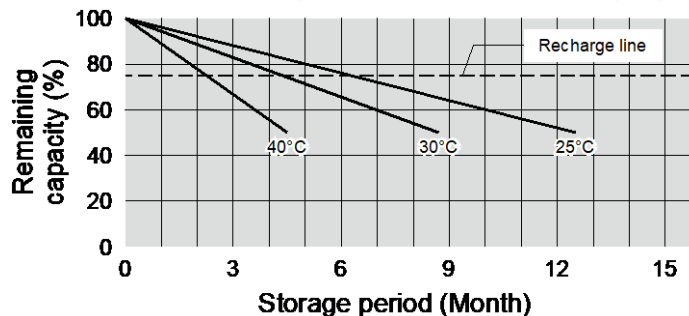

<Description>

When the battery is stored at the storage temperature of 25°C, the battery self-discharges (and the battery level lowers) to approximately 80% over half a year, and to approximately 50% over a year.

Higher the storage temperature is, faster the battery will self-discharge.

Storage temperature	Auxiliary charging interval
40°C or less	2 months
30°C or less	4 months
25°C or less	6 months

9-4 China RoHS Information

部件名称 Component Name	产品中有害物质的名称及含量 Name and content of hazardous substances in products					
	铅 (Pb)	汞 (Hg)	镉 (Cd)	六价铬 (Cr(VI))	多溴联苯 (PBB)	多溴二苯醚 (PBDE)
机械组件 Mechanical Assemblies	×	○	○	○	○	○
电线组件 Wire Assemblies	×	○	○	○	○	○
印刷电路板 Printed Circuit Boards	×	○	○	○	○	○
焊料 Solder	○	○	○	○	○	○
紧固件 Fasteners	○	○	○	○	○	○
电池模块 Battery Pack	×	○	○	○	○	○
其他机械部件 Other Mechanical Items	×	○	○	○	○	○

本表格依据 SJ/T11364 的规定编制。

This table was developed according to the provisions of SJ/T 11364.

- : 表示该有害物质在该部件所有均质材料中的含量均在 GB/T 26572 规定的限量要求以下。
The content of such hazardous substance in all homogeneous materials of such component is below the limit required by GB/T 26572.
- ×: 表示该有害物质至少在该部件的某一均质材料中的含量超出 GB/T 26572 规定的限量要求。
The content of such hazardous substance in a certain homogeneous materials of such component is beyond the limit required by GB/T 26572.

有毒有害材料 Hazardous Substance	最高浓度值 (MCV) MCV
Pb, Hg, Cr ⁶⁺ , PBB, PBDE	1,000 PPM
Cd	100 PPM

依照中国《电子信息产品污染管制管理办法》(第 39 号), 现标明 OMRON 相关产品中可能含有的有毒、有害物质或元素的名称与含量。

In accordance with China's Administrative Measures on the Control of Pollution Caused by Electronic Information Products (EIP) # 39, also known as China RoHS, the information is provided regarding the names and concentration levels of Toxic Substances (TS) or Hazardous Substances (HS) which may be contained in OMRON products relative to the EIP standards set by China's Ministry of Information Industry (MII).

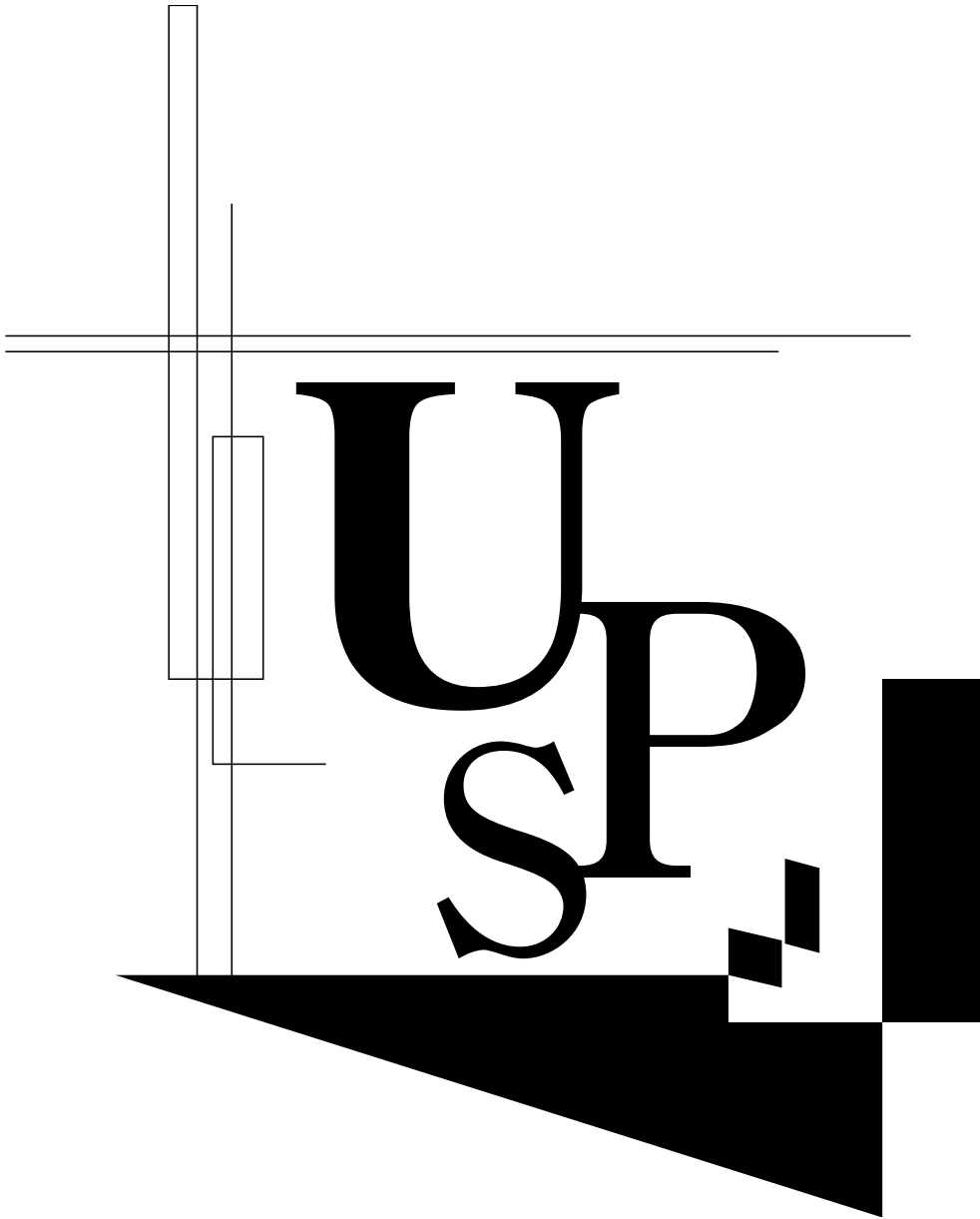

No part or whole of this manual may be reproduced without permission.
The contents of this manual are subject to change without notice.

OMRON SOCIAL SOLUTIONS CO.,LTD.